

Checkbooks, Cookbooks, and Matchbooks

Vadim Ponomarenko

Department of Mathematics and Statistics
San Diego State University

Sam Houston State University August 24, 2011

<http://www-rohan.sdsu.edu/~vadim/checkbooks.pdf>



Shameless advertising

Please encourage your students to apply to the
San Diego State University Mathematics REU.

<http://www.sci.sdsu.edu/math-reu/index.html>

This work was done jointly with undergraduate Ryan Rosenbaum, graduate students Donald Adams and Andreas Philipp, and postdoc David Gryniewicz.



Ground Rules

This talk is all natural: $\{0, 1, 2, \dots\}$.

Congruences: $a \equiv b \pmod{n}$ means $n > 0$ and $n \mid (a - b)$.



Ground Rules

This talk is all natural: $\{0, 1, 2, \dots\}$.

Congruences: $a \equiv b \pmod{n}$ means $n > 0$ and $n \mid (a - b)$.



Routing Numbers

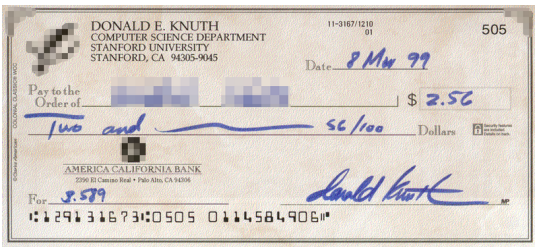

Routing number: 129131673

$x_1 = 1, x_2 = 2, x_3 = 9, \dots, x_9 = 3$ satisfy:

$$3x_1 + 7x_2 + x_3 + 3x_4 + 7x_5 + x_6 + 3x_7 + 7x_8 + x_9 \equiv 0 \pmod{10}$$



Routing Numbers

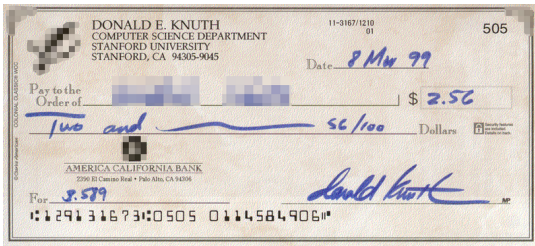

Routing number: 129131673

$x_1 = 1, x_2 = 2, x_3 = 9, \dots, x_9 = 3$ satisfy:

$$3x_1 + 7x_2 + x_3 + 3x_4 + 7x_5 + x_6 + 3x_7 + 7x_8 + x_9 \equiv 0 \pmod{10}$$



ISBN codes



ISBN10: 3126754953

ISBN13: 9783126754958

ISBN10 satisfies

$$10x_1 + 9x_2 + 8x_3 + 7x_4 + 6x_5 + 5x_6 + 4x_7 + 3x_8 + 2x_9 + x_{10} \equiv 0 \pmod{11}$$

ISBN13 satisfies $x_1 + 3x_2 + x_3 + 3x_4 + \dots + 3x_{10} + x_{11} \equiv 0 \pmod{10}$



ISBN codes



ISBN10: 3126754953

ISBN13: 9783126754958

ISBN10 satisfies

$$10x_1 + 9x_2 + 8x_3 + 7x_4 + 6x_5 + 5x_6 + 4x_7 + 3x_8 + 2x_9 + x_{10} \equiv 0 \pmod{11}$$

ISBN13 satisfies $x_1 + 3x_2 + x_3 + 3x_4 + \cdots + 3x_{10} + x_{11} \equiv 0 \pmod{10}$



UPC Numbers



UPC number: 639382000393

Satisfies $3x_1 + x_2 + 3x_3 + 1x_4 + \cdots + 3x_{11} + x_{12} \equiv 0$
(mod 10)



Postnet Barcodes

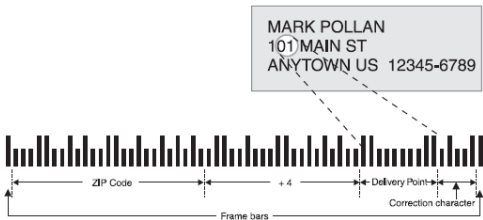

Postnet number: 123456789014

Satisfies $x_1 + x_2 + x_3 + \dots + x_{12} \equiv 0 \pmod{10}$



VIN codes

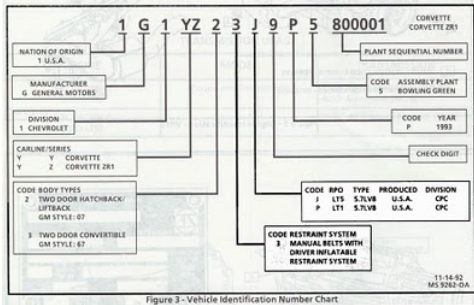

VIN (translated): 17189231975800001

Satisfies

$$8x_1 + 7x_2 + 6x_3 + 5x_4 + 4x_5 + 3x_6 + 2x_7 + 10x_8 + 10x_9 + 9x_{10} + 8x_{11} + 7x_{12} + 6x_{13} + 5x_{14} + 4x_{15} + 3x_{16} + 2x_{17} \equiv 0 \pmod{11}$$



Another Obstacle

We focus henceforth on finding distinct solutions.

$x_1 - x_2 \equiv 0 \pmod{n}$ has no solutions.

We call this the **Bivariate Obstacle**.



Today's Other Theorem

Thm: [GPP] A multilinear modular equation has a distinct solution if and only if, for all equivalent equations, neither the subgroup nor the bivariate obstacles hold.

Proof Strategy: Replace $\mathbb{Z}/n\mathbb{Z}$ with a general finite abelian group. One more obstacle arises, for Klein 4-group.



Today's Other Theorem

Thm: [GPP] A multilinear modular equation has a distinct solution if and only if, for all equivalent equations, neither the subgroup nor the bivariate obstacles hold.

Proof Strategy: Replace $\mathbb{Z}/n\mathbb{Z}$ with a general finite abelian group. One more obstacle arises, for Klein 4-group.



For Further Reading



D. Adams, P

Distinct Solutions to a Linear Congruence.

Involve 3 (3), 2010.



D. Gryniewicz, A. Philipp, P

Arithmetic-Progression-Weighted Subsequence Sums.

To appear in *Israel Math Journal*.



Preprints available at:

<http://www-rohan.sdsu.edu/~vadim/research.html>

