

# Attention Please

---

- Weekly Exercise (P93 on text book)  
2-15; 2-18; 2-19; 2-22; 2-25(a)&(b)
- Midterm Exam1 is scheduled on Feb. 27 Monday in class.
- On Feb. 22, I will spend one lecture to help you prepare Midterm Exam1. Don't miss it!

# Systematic Simplification

---

- A *Prime Implicant* is a product term obtained by combining the **maximum possible** number of adjacent squares in the map into a rectangle with the number of squares a power of 2.
- A prime implicant is called an *Essential Prime Implicant* if it is the **only** prime implicant that covers (includes) **one or more** minterms.
- Prime Implicants and Essential Prime Implicants can be determined by inspection of a K-Map.
- A set of prime implicants "*covers all minterms*" if, for each minterm of the function, at least one prime implicant in the set of prime implicants includes the minterm.

# Example of Prime Implicants

- Find ALL Prime Implicants

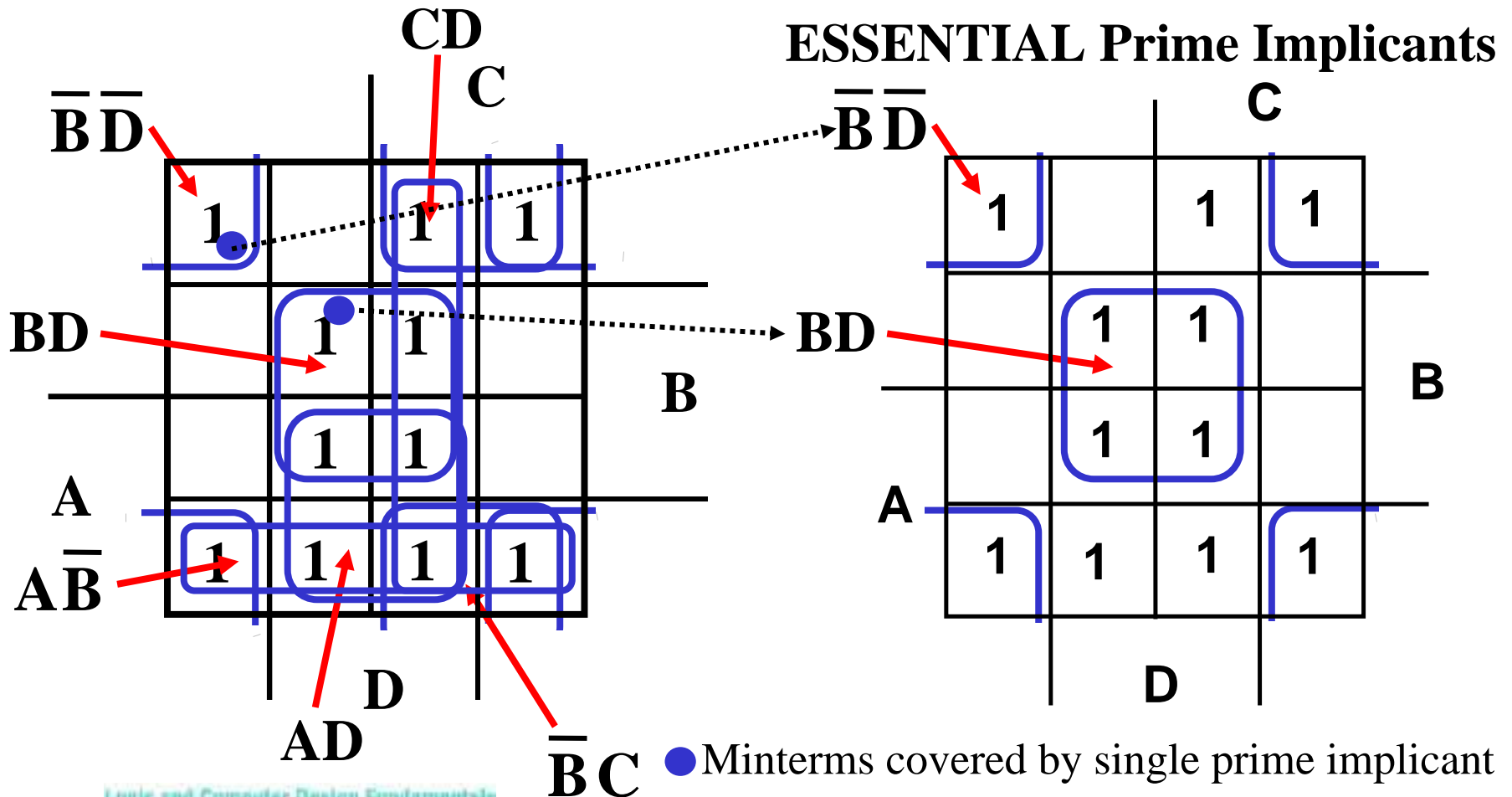

# Prime Implicant Practice

---

- Find all prime implicants for:  
 $F(A, B, C, D) = \Sigma_m(0, 2, 3, 8, 9, 10, 11, 12, 13, 14, 15)$

# Another Example

---

- Find all prime implicants for:  
 $G(A, B, C, D) = \Sigma_m(0, 2, 3, 4, 7, 12, 13, 14, 15)$ 
  - Hint: There are seven prime implicants!

# Don't Cares in K-Maps

---

- Sometimes a function table or map contains entries for which it is known:
  - the input values for the minterm will never occur, or
  - The output value for the minterm is not used
- In these cases, the output value need not be defined
- Instead, the output value is defined as a “don't care”
- By placing “don't cares” ( an “x” entry) in the function table or map, the cost of the logic circuit may be lowered.
- **Example 1:** A logic function having the binary codes for the BCD digits as its inputs. Only the codes for 0 through 9 are used. The six codes, 1010 through 1111 never occur, so the output values for these codes are “x” to represent “don't cares.”

# Example: BCD "5 or More"

- The map below gives a function  $F1(w,x,y,z)$  which is defined as "5 or more" over BCD inputs. With the don't cares used for the 6 non-BCD combinations:

A 4x4 Karnaugh map for the function F1(w,x,y,z). The vertical axis is labeled 'w' and the horizontal axis is labeled 'z'. The top horizontal axis is labeled 'y' and the right vertical axis is labeled 'x'. The cells are numbered 0 through 15. The values in the cells are: (0,0)=0, (0,1)=0, (0,3)=0, (0,2)=0; (1,0)=0, (1,5)=1, (1,7)=1, (1,6)=1; (2,12)=X, (2,13)=X, (2,15)=X, (2,14)=X; (3,8)=1, (3,9)=1, (3,11)=X, (3,10)=X. Blue circles highlight prime implicants: a circle around (1,5), (1,7), (1,6); a circle around (2,13), (2,15); a circle around (2,12), (2,14); a circle around (3,8), (3,9).

	y				
	0	1	3	2	
	0 <sub>4</sub>	1 <sub>5</sub>	1 <sub>7</sub>	1 <sub>6</sub>	x
	X <sub>12</sub>	X <sub>13</sub>	X <sub>15</sub>	X <sub>14</sub>	
w	1 <sub>8</sub>	1 <sub>9</sub>	X <sub>11</sub>	X <sub>10</sub>	
	z				

$$F1(w,x,y,z) = w + xz + xy \quad G = 7$$

- This is much lower in cost than F2 where the "don't cares" were treated as "0s."

# Optimization Algorithm

---

- Find all prime implicants.
- Include all essential prime implicants in the solution
- Select a minimum cost set of non-essential prime implicants to cover all minterms not yet covered:
  - Obtaining an optimum solution: See Reading Supplement - More on Optimization
  - Obtaining a good simplified solution: Use the Selection Rule

# Prime Implicant Selection Rule

---

- **Minimize the overlap among prime implicants as much as possible. In particular, in the final solution, make sure that each prime implicant selected includes at least one minterm not included in any other prime implicant selected.**

# Selection Rule Example

- Simplify  $F(A, B, C, D)$  given on the K-map.**

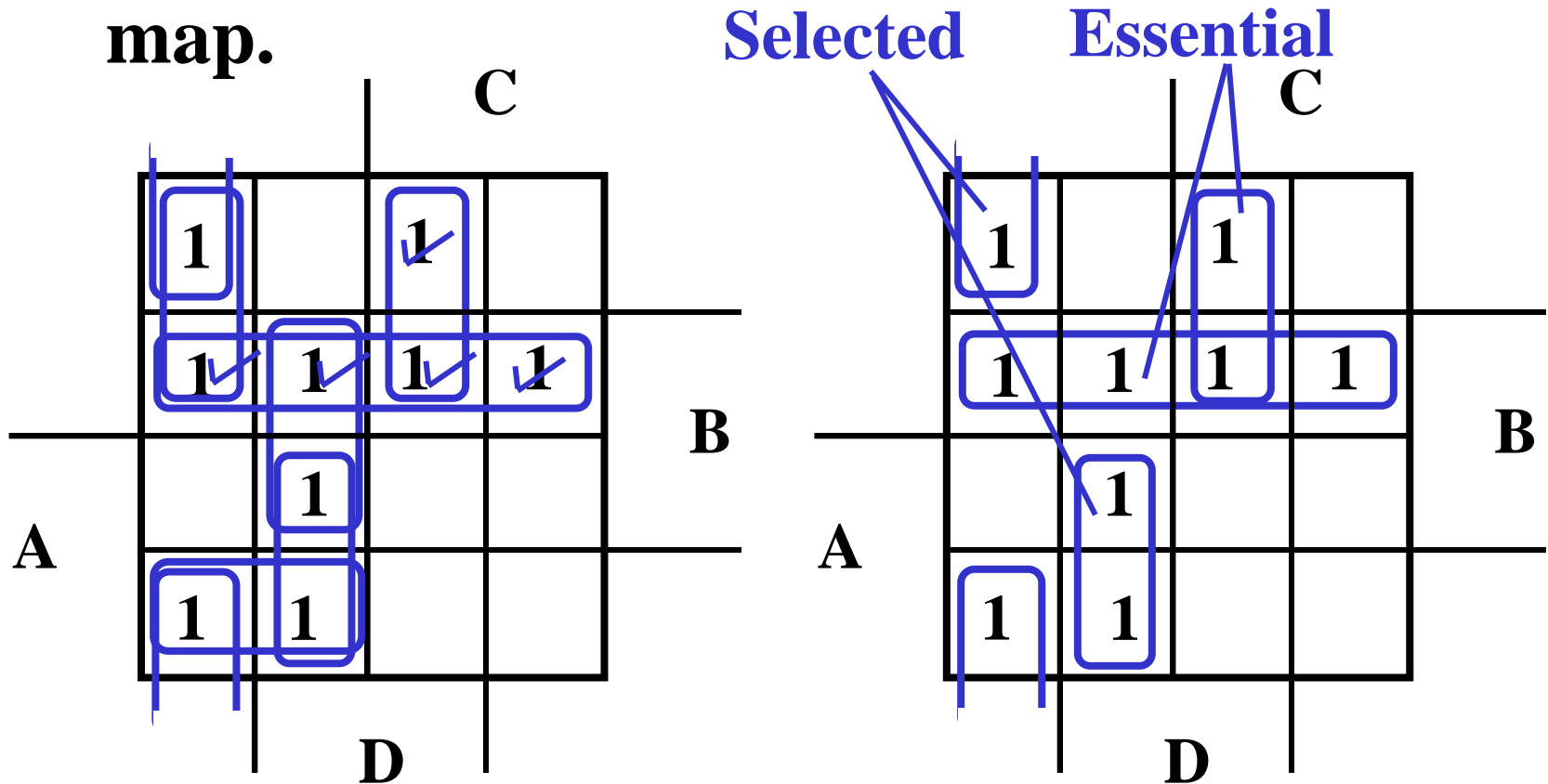

✓ Minterms covered by essential prime implicants

# Selection Rule Example with Don't Cares

- Simplify  $F(A, B, C, D)$  given on the K-map.

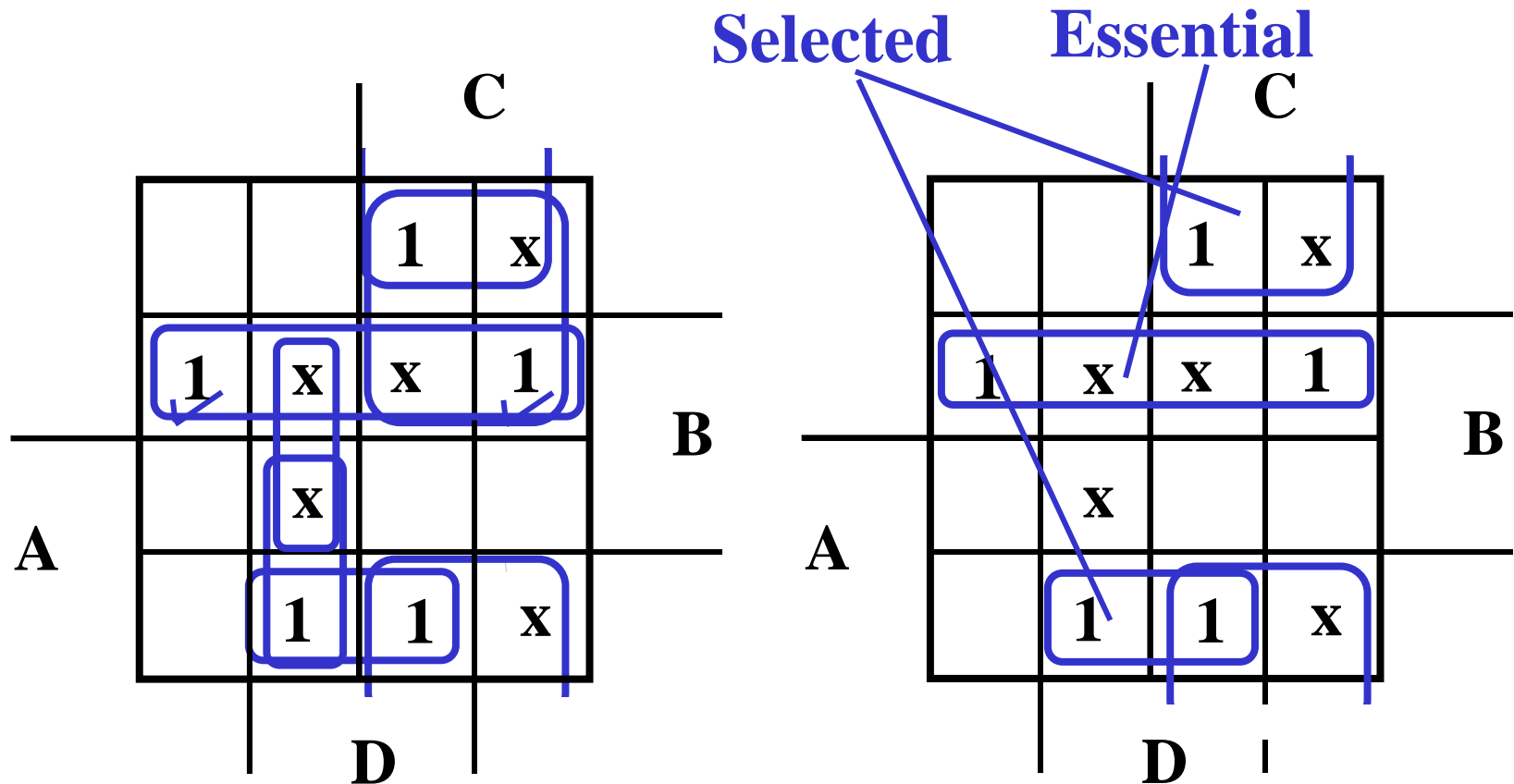

✓ Minterms covered by essential prime implicants

# Common Mistakes (1)

- Groups may not include any cell containing a **zero**.

A \ B	0	1
0	0	
1	1	

WRONG ✗

A \ B	0	1
0	0	
1	1	1

RIGHT ✓

# Common Mistakes (2)

- Groups may be horizontal or vertical, but not **diagonal**.

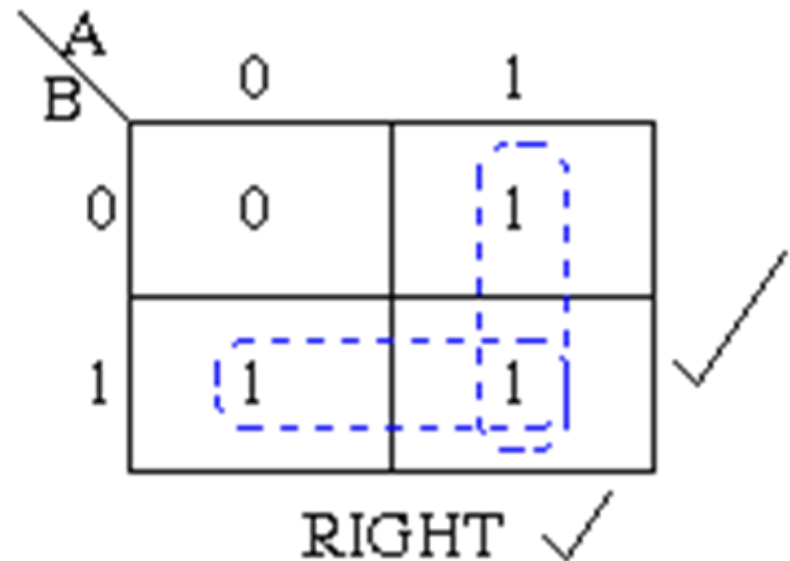
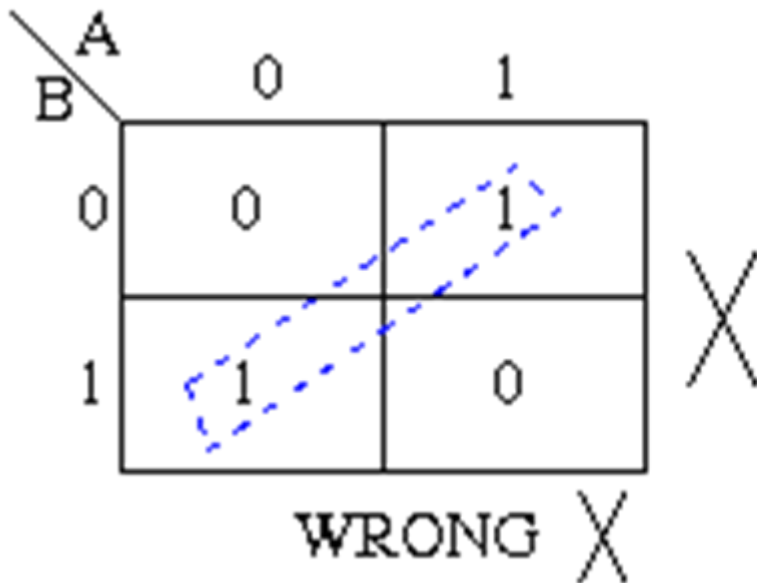

# Common Mistakes (3)

- Groups must contain 1, 2, 4, 8, or in general  $2^n$  cells.

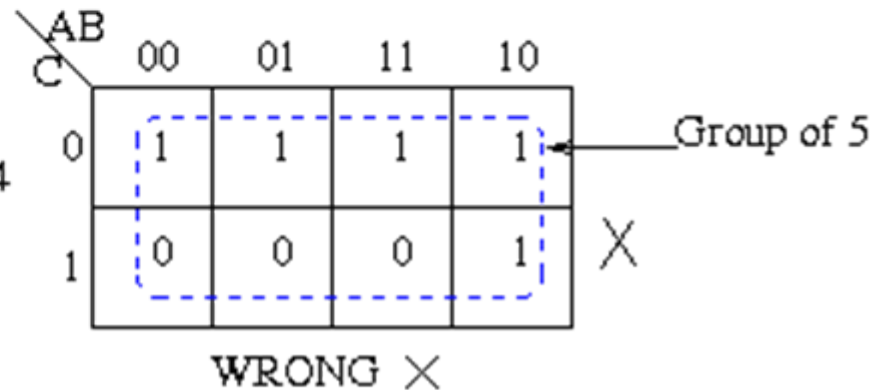
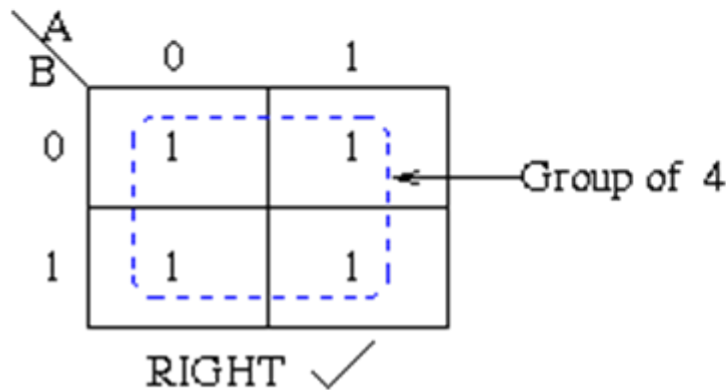
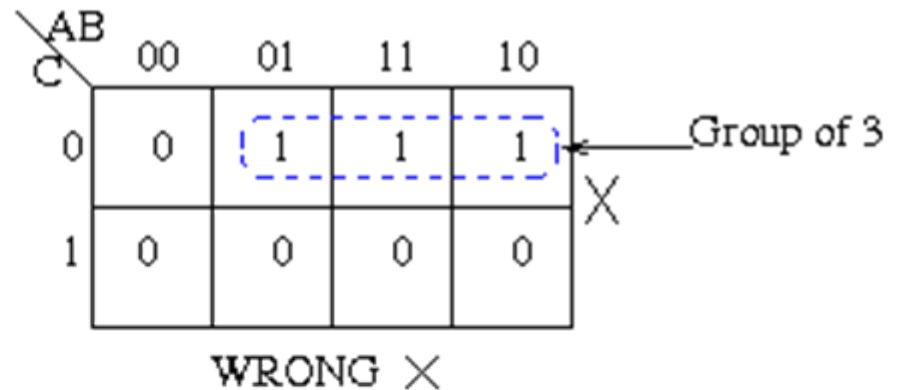
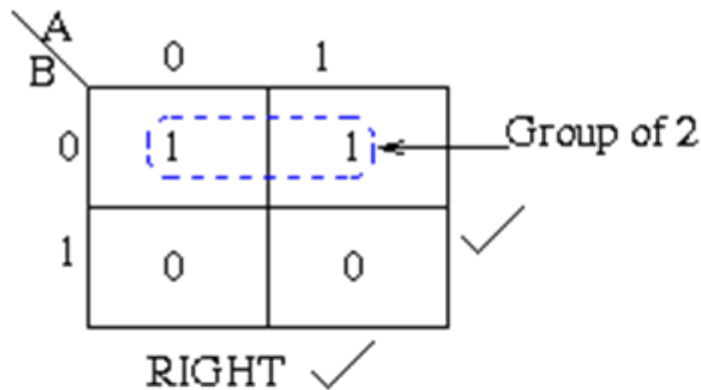

# Common Mistakes (4)

- Each group should be as large as possible.

$\backslash AB$	00	01	11	10
C				
0	1	1	1	1
1	0	0	1	1

RIGHT ✓

$\backslash AB$	00	01	11	10
C				
0	1	1	1	1
1	0	0	1	1

WRONG ✗

(Note that no Boolean laws broken, but not sufficiently minimal)

# Common Mistakes (5)

- Groups may overlap.

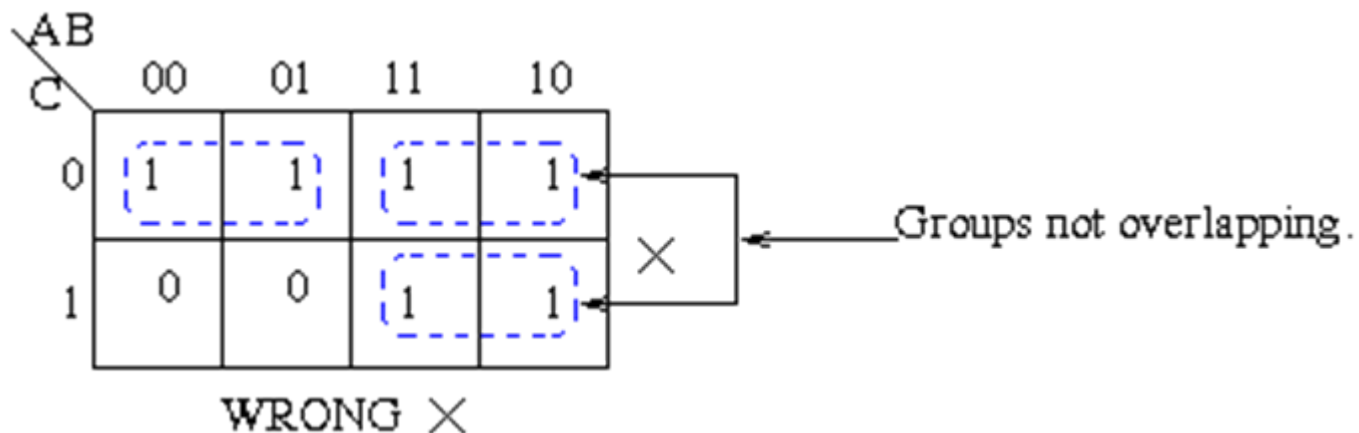
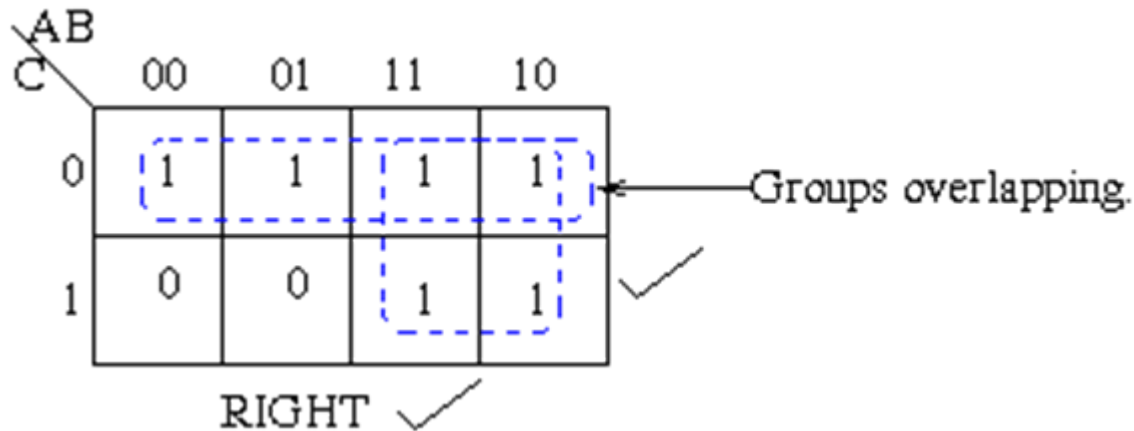

# Common Mistakes (6)

- Groups may wrap around the table. The leftmost cell in a row may be grouped with the rightmost cell and the top cell in a column may be grouped with the bottom cell.

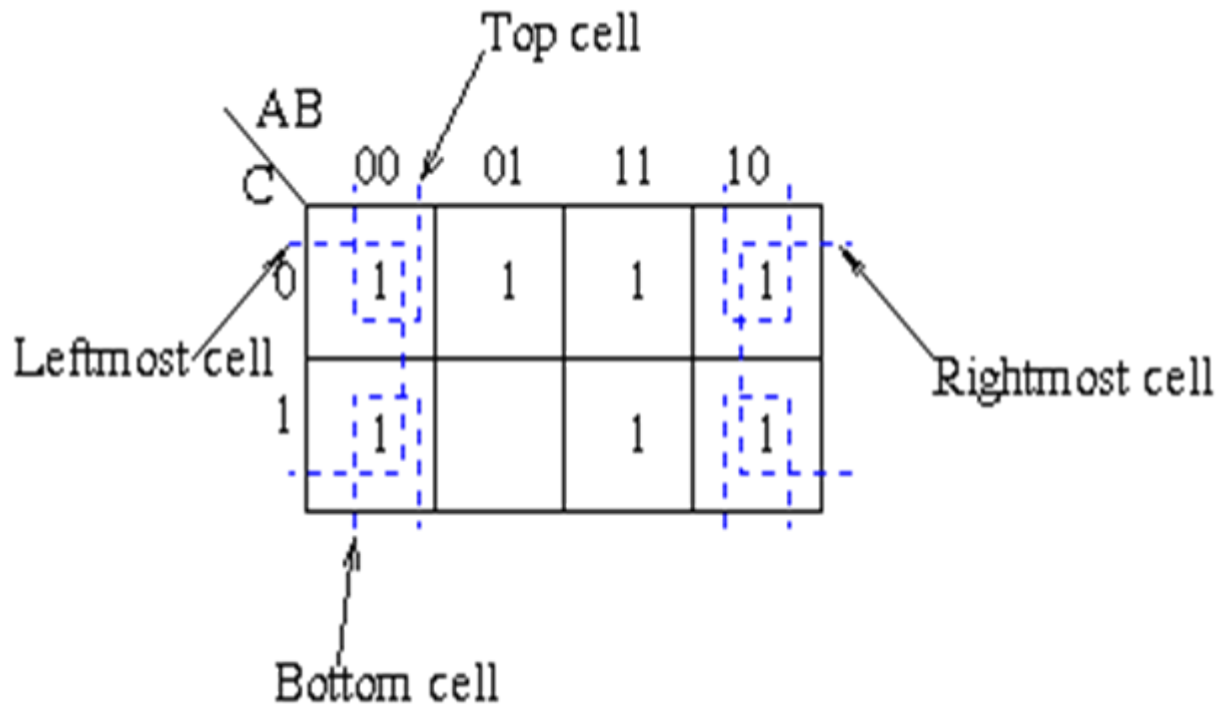

# Common Mistakes (7)

- There should be as few groups as possible.

$\backslash AB$	00	01	11	10
C				
0	1	1	1	1
1	0	0	1	1

RIGHT ✓

$\backslash AB$	00	01	11	10
C				
0	1	1	1	1
1	0	0	1	1

WRONG ✗

# Avoid Common Mistakes

---

- No zeros allowed.
- No diagonals.
- Only power of 2 number of cells in each group.
- Groups should be as large as possible.
- Every one must be in at least one group.
- Overlapping allowed.
- Wrap around allowed.
- Fewest number of groups possible.

# Terms of Use

---

- **© 2004 by Pearson Education, Inc. All rights reserved.**
- **The following terms of use apply in addition to the standard Pearson Education [Legal Notice](#).**
- **Permission is given to incorporate these materials into classroom presentations and handouts only to instructors adopting Logic and Computer Design Fundamentals as the course text.**
- **Permission is granted to the instructors adopting the book to post these materials on a protected website or protected ftp site in original or modified form. All other website or ftp postings, including those offering the materials for a fee, are prohibited.**
- **You may not remove or in any way alter this Terms of Use notice or any trademark, copyright, or other proprietary notice, including the copyright watermark on each slide.**
- **[Return to Title Page](#)**