

The Lexical Integrity of Japanese Causatives

Christopher D. Manning
University of Sydney

Ivan A. Sag
Stanford University

Masayo Iida
Fujitsu Software Co.

August 7, 1998

1 Introduction

Grammatical theory has long wrestled with the fact that causative constructions exhibit properties of both single words and complex phrases. However, as Paul Kiparsky has observed, the distribution of such properties of causatives is not arbitrary: ‘construal’ phenomena such as honorification, anaphor and pronominal binding, and quantifier ‘floating’ typically behave as they would if causatives were syntactically complex, embedding constructions; whereas case marking, agreement and word order phenomena all point to the analysis of causatives as single lexical items.¹

Although an analysis of causatives in terms of complex syntactic structures has frequently been adopted in an attempt to simplify the mapping to semantic structure, we believe that motivating syntactic structure based on perceived semantics is questionable because in general a syntax/semantics homomorphism cannot be maintained without vitiating syntactic theory (Miller 1991). Instead, we sketch a strictly lexical theory of Japanese causatives that deals with the evidence offered for a complex phrasal analysis. Such an analysis makes the phonology, morphology and syntax parallel, while a mismatch occurs with the semantics. The conclusions we will reach are given in (1):

- (1) a. Japanese causatives must be treated as single verbal forms with complex morphological structure. The causative morpheme should not be treated as a higher predicate as it is in most transformational/GB analyses (following Kuroda (1965)), and in Gunji (this volume).

¹This paper has had a long gestation. Initial arguments for a lexicalist treatment of Japanese causatives were gathered in a seminar class run by Ivan Sag in 1990. Participants included Makoto Kanazawa, Patrick O’Neill, and Whitney Tabor. The details of the analysis were changed and a new paper written by the listed authors and O’Neill for presentation at the 1994 LSA Annual Meeting in Boston. The present version, which includes new data and extensive analytic revisions, was prepared by Manning and Sag, in regular consultation with Iida. We thank earlier contributors, and in addition are grateful to the following for comments and discussion: Emily Bender, Gosse Bouma, Ann Copestake, Kaz Fukushima, Takao Gunji, Rob Malouf, Tsuneko Nakazawa, Jerry Sadock, and Peter Sells. We’re not quite sure who should be held responsible for any remaining errors.

- b. The construal phenomena that seem to motivate an analysis of Japanese causatives in terms of embedded constituent structures can be explained in terms of hierarchical lexical argument structures.
- c. It is possible to maintain a strictly lexical analysis, once a suitable conception of lexical structure and organization is adopted.

Our analysis, which provides a simple alternative to current proposals making extensive use of verb-embedding, functional projections and empty categories, is cast within the framework of Head-driven Phrase Structure Grammar (HPSG), but is easily adapted to other lexical frameworks, such as LFG and Categorical Grammar, and is similar in some respects to lexical GB accounts like those offered by Miyagawa (1980) and Kitagawa (1986).

2 The Data

Japanese causative verbs are formed by adding *-(s)ase* to a verb stem, as in (2). The causer is marked with the nominative case particle *ga*, and the causee is marked with the dative particle *ni* (or optionally the accusative particle *o* if the stem was intransitive).

- (2) Yumiko *ga* Ziroo *ni* sono hon *o* yom-ase-ta.
 Yumiko NOM Ziroo DAT that book ACC read-CAUS-PAST
 ‘Yumiko made/let Ziroo read that book.’

2.1 Phonological and Lexical Arguments

The intuition of the native Japanese speaker regarding the “wordhood” of a causative verb such as *tazune-sase-ru* ‘visit-CAUS-PRES’ is clear – these verbs are single words. This intuition is supported by a number of phonological observations that have been made by Kitagawa (1986), McCawley (1968), Poser (1984), and others. We present here arguments from allomorphy and reduplication, and suggestive evidence from accentuation (for similar suggestive evidence from voicing spread and downdrift see Kitagawa (1986)).

2.1.1 Allomorphy

The consonant deletion giving *-sase* → *-ase* after consonant stems:

- (3) a. tabe -sase -ru
 eat -CAUS -PRES
- b. kak -ase -ru
 write -CAUS -PRES

is idiosyncratic rather than a general phonological rule (the general phonological rules would rather yield epenthesis, i.e., *kakisaseru*). This argues that *-sase* is lexically attached.

2.1.2 Reduplication

Repetition of a certain action can be expressed by reduplicating the verb (4a). Such reduplication with causatives cannot exclude the verb stem (4c):

- (4) a. gohan o tabe tabe
rice ACC eat eat
'eating rice repeatedly'
- b. ?gohan o tabe-sase tabe-sase
rice ACC eat-CAUS eat-CAUS
'causing someone to eat rice repeatedly'
- c. *gohan o tabe-sase sase
rice ACC eat-CAUS CAUS

This argues that *tabe-sase* must be formed in the lexicon, since reduplication is a lexical process (Marantz 1982).²

2.1.3 Accentuation

Kitagawa (1986) presents a number of further arguments based on the theory of Lexical Phonology (Kiparsky 1982) that show that the past tense morpheme *-ta* and the desiderative morpheme *-ta(i)* attach to their host in the lexicon. This host can be either a verb root or the causative morpheme (among other things). For instance, observe the following pattern of accentuation (McCawley 1968, Chew 1961):

- (5) a. tabé-ru (eat-PRES)
b. tábe-ta (eat-PAST)
c. tabe-sasé-ru (eat-CAUS-PRES)
d. tabe-sáse-ta (eat-CAUS-PAST)

Miyagawa (1989) and Kitagawa (1986) argue that under the theory of Lexical Phonology, these accentual alternations show that the past tense morpheme attaches lexically. On the assumption that the causative morpheme attaches to a verb stem before the final tense morpheme, then this evidence would show that the causative morpheme also attaches lexically. However, we do not view such arguments as deciding the structure of causatives. One could accept the lexical attachment of the tense and desiderative morphemes and still deny the additional assumption mentioned above. We do not know of further convincing phonological evidence for the lexical analysis of Japanese causatives beyond that presented in Sections 2.1.1 and 2.1.2.³

²The awkwardness of (4b) is presumably due to pragmatic factors.

³Other putative arguments, like noting that the accent on *-masu* overrides a stem affix across a causative affix, also fail because the same accentual phenomena occur with verbal compounds like *yonde miru*. Poser (class, Stanford, 1993) suggests as a further argument that normally any word can be an intonational minor phrase (with focus intonation) in the sense of McCawley (1968) but that *-sase* cannot be one. We thank Bill Poser for discussion of the phonological data.

2.1.4 Lexicalization, idioms, and blocking

Miyagawa (1980, 1989) presents a variety of arguments from idioms, blocking, and idiosyncratic causatives (that have undergone semantic drift or which have survived while the base verb has disappeared) to argue for a lexical analysis of Japanese causatives. We take many of these arguments as suggestive, but not fully convincing, because there are clear cases in the literature where blocking and semantic drift occur in the syntax (e.g., Poser (1992)).

2.2 Morphosyntactic Arguments

A large number of morphosyntactic arguments favor the lexical analysis.

2.2.1 Subject Honorification

When the person denoted by the subject NP is socially superior to the speaker, the verb that governs that subject conventionally bears subject honorification morphology, *o-* and *ni nar-*, as illustrated in (6a), which involves the syntactically complex *-te yaru* construction.⁴

Only the main verb can bear subject honorification morphology in such constructions, as shown by the ungrammaticality of (6b).

- (6) a. Tanaka-sensei ga kodomo ni hon o yonde o-yari ni nat-ta.
Prof. Tanaka NOM child DAT book ACC read-GER HON-give become-PAST
'Prof. Tanaka gave the child the favor of reading a book.'
- b.*Tanaka-sensei ga kodomo ni hon o o-yonde yari ni nat-ta.
Prof. Tanaka NOM child DAT book ACC HON-read-GER give become-PAST
'Prof. Tanaka gave the child the favor of reading the book.'

In contrast, a causative verb as a whole can bear subject honorification morphology, whereas the causative morpheme *-(s)ase* alone cannot bear that morphology, as shown in (7):

- (7) a. Tanaka-sensei ga Suzuki ni hon o o-yom-ase ni nat-ta.
Prof. Tanaka NOM Suzuki DAT book ACC HON-read-CAUS become-PAST
'Prof. Tanaka made Suzuki read a book.'
- b.*Tanaka-sensei ga Suzuki ni hon o yomi o-sase ni nat-ta.
Prof. Tanaka NOM Suzuki DAT book ACC read HON-CAUS become-PAST
'Prof. Tanaka made Suzuki read a book.'

This observation argues for a lexical analysis of the causative (Sugioka 1984:51). If the construction were syntactically complex, the honorific prefix should precede only the causative morpheme, in parallel to (6a). Put differently, in an analysis where causatives involve embedded complement clauses, it is quite mysterious how the honorific prefix *o-* gets to attach to the verb in the lower clause.

⁴We don't gloss the word *ni* which appears in the subject honorific construction because we are not sure what it is. Accentuation suggests that *yari* is a deverbal noun, though it could conceivably be the segmentally identical verbal *renyookei*. It is reasonably certain, though, that the morpheme *o-* before *yari* is a prefix attached to the word *yari*.

Note finally that the other possibility, where honorification occurs inside causativization in the morphology, as in (8), provides no problems for a lexical account. For such a form, honorification occurs to the stem, and then this larger stem is causativized. The resulting pattern whereby the causee is honored falls out of the account we present below, and would be expected to fall out of almost any lexical account.⁵

- (8) Syukutyoku no yoomuin ga kootyoo-sensei ni yoomuin-situ de
 night.duty GEN janitor NOM principal DAT night.duty.room in
 sibiraku o-yasumi ni nar-ase-te sasiage-ta (koto)
 a.little HON-rest become-CAUS-GER give-PAST (fact)
 ‘The janitor on night duty let the principal take a rest in the night duty room for a little while.’

2.2.2 The Double-O Constraint

Example (9) shows that the causative construction observes the double-*o* constraint (a prohibition on multiple direct objects, marked by the particle *o*: see Harada (1973), Poser (1989)). When the embedded verb is transitive, the causee cannot be marked with accusative because this would yield two *o*-marked NPs.

- (9) Taroo ga Ziroo *o/ni Kazuo o home-sase-ta.
 Taro NOM Ziro ACC/DAT Kazuo ACC praise-CAUS-PAST
 ‘Taro made Ziro praise Kazuo.’

The case marking in the morphological causative thus parallels that of the lexical causative (10a) and that of simplex three-argument verbs (10b):

- (10) a. Taroo ga Ziroo *o/ni e o mise-ta.
 Taro NOM Ziro ACC/DAT picture ACC show-PAST
 ‘Taroo showed a picture to Ziroo.’
 b. Taroo ga Ziroo *o/ni e o age-ta.
 Taro NOM Ziro ACC/DAT picture ACC give-PAST
 ‘Taroo gave a picture to Ziroo.’

Only the lexical analysis predicts the case marking of causatives from the general case marking requirements for three-argument verbs without a further stipulation.

2.2.3 Nominalization

Nominalizations also support the lexical approach. Suffixation of *-kata* creates a nominal meaning ‘way of’, and can apply to causatives (Saiki 1987), as illustrated in (11b).

- (11) a. kodomo ni hon o yom-ase-ta.
 child DAT book ACC read-CAUS-PAST
 ‘(I) caused the child to read a book.’

⁵Such forms are often pragmatically awkward, however, doubtless due to the incongruity of simultaneously honoring someone and making them the causee.

- b. (?kodomo e no) hon no yom-ase-kata
 child DAT GEN book GEN read-CAUS-way
 ‘the way to cause (the child) to read a book’

The genitive case-marking on the object *hon* shows that *yomasekata* is a noun. Under a nonlexical analysis of causatives we would expect to nominalize only *-(s)ase* and to get accusative case *o* after *hon*. Moreover, it would be difficult to account for the accent deleting properties of *-kata*, within a theory such as Lexical Phonology, unless *yom-ase-kata* is analyzed as a single word.⁶

2.2.4 Question-answer pairs

A question with biclausal structure in Japanese is generally answered by repetition of the higher verb:

- (12) a. John ga iku yoo ni si-ta ka?
 John NOM go-PRES (COMP) do-PAST Q
 ‘Have (you) arranged for John to go?’
 b. Si-ta (yo).
 do-PAST
 ‘Yes, I have.’ *lit.* ‘Did.’
- (13) a. John ni [it-te kure-ru yoo ni] tanon-da ka?
 John DAT [go-GER give-PRES (COMP)] ask-PAST Q
 ‘Have (you) asked John to go?’
 b. Tanon-da (yo).
 ask-PAST
 ‘Yes, I have.’ *lit.* ‘Asked.’

But one cannot answer a question formed with a causative construction by just a causative morpheme. Rather one must repeat the whole causative form (i.e. including the putative embedded verb):

- (14) a. John o ik-ase-ta ka?
 John ACC go-CAUS-PAST Q
 ‘Have you cause John to go?’
 b. *Sase-ta.
 CAUS-PAST

This behavior requires a special stipulation on the nonlexical account. It is predicted if the causativized verb is treated as a lexical item.

⁶We thank Peter Sells and Bill Poser for most of the ideas that underlie this section. It should be mentioned, though, that this argument only shows that the noun *yomasekata* is a word, and not necessarily that the corresponding verbal forms are, as was pointed out to us by a reviewer.

2.2.5 Word Order

When a causative verb takes a theme argument and a location argument, the unmarked order is location-theme, not theme-location. For instance, in a pair like:

- (15) a. no ni hana o sak-ase-ru
field in flower ACC bloom-CAUS-PRES
'to cause flowers to bloom in fields'
- b. hana o no ni sak-ase-ru
flower ACC field in bloom-CAUS-PRES
'to cause flowers to bloom in fields'

the first sentence, which has the location-theme order, is unmarked. The second sentence is somewhat less natural, and seems to be acceptable only when the location argument gets focus interpretation. This observation is unexpected under the nonlexical analysis, because it predicts that the causee argument (here, the theme) should precede all the embedded arguments in the unmarked word order, assuming that the order produced by clausal embedding is the unmarked order. In contrast, this unmarked ordering is predicted under a lexical account where it reflects the normal rules for ordering clausal constituents (Kuno 1973:351).

2.2.6 Potential

Japanese has a morpheme, *-(rar)e* which adds a notion of ability or possibility to the meaning of a verb. When this morpheme is introduced into a clause, an argument which was marked in the accusative may optionally be marked with the nominative:

- (16) a. Mitiko wa hon o yon-da
Mitiko TOP book ACC read-PAST
'Mitiko read the book.'
- b. Mitiko wa hon ga/o yom-e-ru
Mitiko TOP book NOM/ACC read-POT-PRES
'Mitiko can read the book.'

This generalization applies even to potentialized causatives (although the resulting sentences are somewhat less natural):

- (17)?Taroo ga kodomo ni piano ga naraw-ase-rare-nakat-ta (koto)
Taroo NOM child DAT piano NOM learn-CAUS-POT-NEG-PAST (fact)
'(the fact that) Taroo was not able to make the child learn how to play the piano.'

This fact would lack any natural explanation on a nonlexical analysis which treats the third NP in (17) as belonging to an embedded clause. But it follows naturally on the lexical analysis: the third NP is treated as an argument of the potentialized verb, so its case-marking is predicted by the same generalization that specifies the case marking for potentialized simplex verbs, such as in (16b).

2.2.7 Negative polarity items and reciprocals

It is generally accepted that the negative polarity item *sika* ‘except’ can only be licensed by a negative in its own clause (Muraki 1978, Kitagawa 1986:136).⁷ For instance, the following is impossible:

- (18)**Watasi wa [kare ga biiru sika nom-u] to sir-ana-katta.*
I TOP he NOM beer except drink-PRES COMP know-NEG-PAST
*‘I didn’t know that he drinks anything but beer.’

But note now that *sika* is licensed on an argument of the verb stem in a causative, even though the sentential negation occurs after *(s)ase-*:

- (19) *ano ban watasi wa Taroo ni biiru sika nom-ase-na-katta.*
that night I TOP Taroo DAT beer except drink-CAUS-NEG-PAST
‘That night, I made/let Taroo drink only beer.’ *lit.* ‘... not drink except beer.’

This argues that a causative sentence is a single clause. Similar arguments can be made with respect to the reciprocal morpheme *-a(w)*: see Kitagawa (1986:174), although, as noted there, there is considerable variation in the acceptance of reciprocalized causatives.

2.3 Syntactic Puzzles for a Lexical Analysis

Now let us turn to syntactic arguments, which are often taken to favor a non-lexical analysis. We will show that all relevant data can in fact be satisfactorily explained within the lexical analysis we develop. We begin with what we take to be two non-arguments, and then consider in turn data from adverb scope, apparent coordination, binding, and quantifier scope.

2.3.1 Non-arguments from anaphora and intervening particles

Shibatani (1973) argues for a nonlexical analysis on the grounds that the putative pro-VP *soo s-* ‘do so’ may refer to either a whole causation event or the lower predicate. However, many people have expressed skepticism as to whether *soo s-* is a pro-VP (Hinds 1973, Miyagawa 1980). It is not the case that *soo s-* always takes a VP antecedent, since the antecedent can be an event expressed by two conjoined sentences in a previous discourse:

- (20) A: *Taroo wa Yamada-sensei ni ai ni it-ta.*
Taroo TOP Yamada-teacher DAT meet PURP go-PAST
‘Taroo went to see Prof. Yamada.’

Suisenzyoo o kaite morau yoo tanon-da.
recommendation ACC write receive COMP ask-PAST
‘He asked for a letter of recommendation to be written for him.’

B: *Hanako mo soo si-ta.*
Hanako also so do-PAST
‘Hanako did so, too.’

⁷ *Sika* cooccurs with a negative verb as an NPI. It is generally translated as ‘only’ in English in a positive sentence.

This suggests that the antecedent of *soo suru* might better be described in terms of the cognitive structure of events than via syntactic notions of constituency.

Kuroda (1981) argues for a syntactic analysis of causatives on the basis of the ability of the negative morpheme *na-* and certain particles such as *mo* ‘also’ and *sae* ‘even’ to intervene between a verb stem and what he takes to be a bare causative morpheme. However, any such argument is greatly weakened by the homonymy between the causative *sase-* and the form that results from adding *(s)ase-* to the verb stem *s-* ‘do’: $s- + (s)ase- \rightarrow s-ase$. See Miyagawa (1989) and particularly Kitagawa (1986:184) for evidence establishing that the allegedly problematic examples are actually manifestations of the causative of *s-* ‘do’.

2.3.2 Adverb Scope

Next, we consider adverb scope. Adverbs in the causative construction can in general be interpreted as modifying either the event denoted by the verb stem or the causation event (Shibatani 1990:314). For instance, (21) is ambiguous.

- (21) Noriko ga Masaru ni gakkoo de hasir-ase-ta.
 Noriko NOM Masaru DAT school at run-CAUS-PAST
 ‘Noriko made Masaru run at school.’

What happened at school may be either the causing event performed by Noriko or the running event caused by Noriko and performed by Masaru.

If adverb scope could be captured only by providing phrase structural domains for an adverb to take scope over, then this would be an argument for a syntactic analysis. Different interpretations could be obtained by assuming different positions for the adverb as illustrated in (22).

- (22) a. [Noriko ga Masaru ni [gakkoo de [[hasir]-ase]]]
 b. [Noriko ga Masaru ni [[gakkoo de [hasir]]-ase]]

On this view, the ambiguity of adverb scope is attributed to the presence of an embedding structure, i.e., the presence of two sentential domains over which adverbs can take scope. Some authors have suggested that, as a result, certain adverb positions have unambiguous scope readings, as shown in (23).

- (23) a. Taroo ga damatte Hanako o heya ni hair-ase-ta.
 Taroo NOM silently Hanako ACC room into enter-CAUS-PAST
 ‘Taroo made Hanako enter the room silently.’ [unambiguous] (Miyagawa 1980)
 b. Damatte Taroo ga Hanako o heya ni hair-ase-ta.
 Silently Taroo NOM Hanako ACC room into enter-CAUS-PAST
 ‘Taroo made Hanako enter the room silently.’ [unambiguous] (Miyagawa 1980)

While a full account of different scope preferences for adverbs is beyond the scope of this paper, we note that various proposed structural restrictions on scope have been contested (e.g., by Kitagawa (1986:89)), and in particular there exist sentences such as those in (24)

in which the adverb appears in structurally the same position as in (23a), but where it can clearly modify either the causation event or the caused event. We will take it as our goal to allow both scopal possibilities for all adverb positions within the clause.

- (24) a. Ken ga hitori de Naomi ni hon o yom-ase-ta.
 Ken NOM by oneself Naomi DAT book ACC read-CAUS-PAST
 ‘Ken made Naomi read the book by herself.’
 ‘Ken made Naomi read the book all by himself.’
- b. Ken ga damatte Naomi o suwar-ase-ta.
 Ken NOM silently Naomi ACC sit-CAUS-PAST
 ‘Ken (silently) made Naomi sit (silently).’
- c. Ken ga zibun no pen de Naomi ni sakubun o kak-ase-ta.
 Ken NOM self GEN pen with Naomi DAT composition ACC write-CAUS-PAST
 ‘Ken (with his own pen) made Naomi write a composition (with her own pen).’

2.3.3 Coordination

It is sometimes assumed that examples like (25) involve coordinate structures, even though there is no overt coordinating particle.

- (25) Ken wa Naomi ni [[hurui kutu o sute]-te
 Ken TOP Naomi DAT old shoes ACC throw-GER
 [atarasii kutu o kaw]] -ase-ta.
 new shoes ACC buy CAUS-PAST
 ‘Ken made Naomi throw away her old shoes and buy new ones.’

Given this assumption, the intended reading suggests, as noted by Gunji (1987), that the VPs *hurui kutu o sute* and *atarasii kutu o kaw* are conjoined and *-sase* is attached to this complex VP.

These sentences, however, cannot provide strong evidence for any nonlexical analysis because the phrases containing a gerundive verb (*sutete*) should be considered as adverbial phrases, rather than as conjoined VPs.⁸ Sentence (26) shows that the phrase ‘throw away old shoes’ is indeed acting as an AdvP because, as an adjunct, it can be placed inside the middle of the other supposed conjunct.⁹

- (26) Ken wa Naomi ni atarasii kutu o [hurui kutu o sute-te] kaw-ase-ta.
 Ken TOP Naomi DAT new shoes ACC old shoes ACC throw buy-CAUS-PAST
 ‘Ken made Naomi throw away old shoes and buy new shoes.’

Asymmetries in the desiderative *ga/o* alternation with these putative “coordinated VPs”, as in (27), provide further support for our claim (Sugioka 1984:168).

⁸We thank Michio Isoda for some of the ideas behind this section.

⁹Some speakers appear to rate this sentence as deserving a ‘?’ in front, while others regard it as fine. At any rate, this situation contrasts clearly with real conjunction.

- (27) a. *Boku wa [kootya ga non-de], [keeki ga tabe]-tai.
 I TOP tea NOM drink-GER cake NOM eat-DESIRE
 ‘I want to drink tea and eat cake.’
- b. *Boku wa [kootya ga non-de], [keeki o tabe]-tai.
 I TOP tea NOM drink-GER cake ACC eat-DESIRE
- c. ?Boku wa [kootya o non-de], [keeki ga tabe]-tai.
 I TOP tea ACC drink-GER cake NOM eat-DESIRE
- d. Boku wa [kootya o non-de], [keeki o tabe]-tai.
 I TOP tea ACC drink-GER cake ACC eat-DESIRE

These asymmetries can be explained by assuming that the first apparent VP is actually an AdvP, and that therefore the case marking of the first object (*kootya* ‘tea’) cannot be affected by properties of the suffix *-tai*.

Thirdly, note the behavior of relativization:

- (28) a. [Ken ga Naomi ni [hurui kutu o sute-te] kaw-ase-ta] atarasii kutu
 Ken NOM Naomi DAT old shoes ACC throw buy-CAUS-PAST new shoes
 ‘the new shoes which Ken made Naomi throw away old shoes and buy’
- b. *[Ken ga Naomi ni [sute-te] atarasii kutu o kaw-ase-ta] hurui kutu
 Ken NOM Naomi DAT throw new shoes ACC buy-CAUS-PAST old shoes
 ‘*the old shoes which Ken made Naomi throw away and buy new ones’

The linearly second object (“new shoes”) can be relativized as in (28a), while the first object (“old shoes”) cannot (28b). If (28a) were actually a case of coordination, then it should be bad as a violation of the Coordinate Structure Constraint.

We hasten to add that the same asymmetries are found with *renyookei* “coordination” as well. The desiderative alternation is illustrated in Sugioka (1984:168), and the same relativization facts hold as above. Our consultants judge scrambling with *renyookei* “coordination” less acceptable than with *-te* form “coordination”, but not impossible. We have no explanation for this at present.

2.3.4 Binding

Binding facts are used as further syntactic evidence to support a non-lexical analysis (Kuroda 1965). It has been widely accepted in the literature that *zibun* (‘self’) is a subject-oriented reflexive. The fact that causee arguments can antecede reflexives as shown in (29) appears to support the embedding-structure analysis of causatives: *zibun*-binding to the causee *Taroo* is possible because *Taroo* is the embedded complement subject.

- (29) Hanako ga Taroo ni zibun no syasin o mi-sase-ta.
 Hanako NOM Taroo DAT self GEN picture ACC see-CAUS-PAST
 ‘Hanako_i made Taroo_j see her_i/his_j picture.’

In contrast, the standard judgement is that there is no ambiguity in (30) where the lexical causative form *miseru* ('show') is used.¹⁰

- (30) Hanako ga Taroo ni zibun no syasin o mise-ta.
 Hanako NOM aro DAT self GEN picture ACC show-PAST
 'Hanako showed Taroo her/*his picture.'

However, as Iida (1992, 1996) has shown, there are good reasons to question the subject-based account of *zibun*-binding. There are many clear counterexamples such as those in (31):

- (31) a. Zibun no buka no husimatu ga Taroo no syusse o samatage-ta.
 self GEN subordinate GEN misconduct NOM Taroo NOM promotion ACC mar-PAST
 'The misconduct of his_i subordinate marred Taroo_i's promotion.'
- b. Taroo wa Ziroo_i ni zibun_i no ayamati o satosi-ta.
 Taroo NOM Ziroo DAT self GEN mistake ACC make-realize-PAST
 'Taroo made Ziroo_i realize his_i mistake.'

But even assuming the subject-based generalization is basically right, it is possible to account for the *zibun*-binding facts without assuming an embedded constituent structure. Within HPSG, binding theory is universally based on argument structure, and hence the subject-orientation of *zibun*-binding need not be stated in terms of constituent structure at all. We return to this matter in section 4.2.1.

Both the overt pronoun *kare* ('he') and the zero pronoun ('little pro') are regarded as pronominal elements and subject to Principle B, as shown in (32):

- (32)*Taroo_i wa Hanako ni kare_i o/∅_i sarakedasi-ta.
 Taroo TOP Hanako DAT he ACC/pro reveal-PAST
 *'Taroo_i revealed him_i to Hanako.'

However, in the morphological causative construction, as shown in (33), *kare* and the zero pronoun in the lower object position may be bound by the subject, but must be disjoint in reference with the dative causee (Kitagawa 1986, Shibatani 1990).

- (33) a. Taroo_i wa Ziroo_j ni kare_{i/*j} o bengo s-ase-ta.
 Taroo TOP Ziroo DAT he ACC defense do-CAUS-PAST
 'Taroo_i made Ziroo_j defend him_{i/*j}.'
- b. Taroo_i wa Ziroo_j ni ∅_{i/*j} bengo s-ase-ta.
 Taroo TOP Ziroo DAT defense do-CAUS-PAST
 'Taroo_i made Ziroo_j defend him_{i/*j}.'

These facts have also been used as evidence to support the embedded analysis of the morphological causative.

¹⁰This conclusion is questioned in some work such as Momoi (1985) and Iida (1992), but we will accept it here.

Although *kare* exhibits various peculiarities that challenge its traditional classification as a simple pronominal,¹¹ we will nonetheless assume here that it falls within the scope of Principle B, and seek to explain this behavior, too, in terms of an argument-structure-based theory of binding.

2.3.5 Quantifier Scope

Finally, we consider a problem about quantifier scope similar to that posed by the interaction of adverbs and causatives. A quantified NP functioning as the lower object of a causative verb form can take intermediate scope, i.e. can take scope over the verb stem, but be outscoped by the causative operator, as illustrated in (34).

- (34) Tanaka-sensei ga gakusei ni sansatu hon o sirabe-sase-ta.
 Prof. Tanaka NOM student DAT three book ACC check-CAUS-PAST
 ‘Prof. Tanaka made the student check three books.’

Perhaps clearer examples of ambiguous scopal interpretation involving the quantifier particle *sika* ‘except’ (recall Section 2.2.7) are discussed by Kitagawa (1986:138). Sentence (35a) can mean either (i) only with respect to beer, I brought about a situation such that Taroo drank it (not the whiskey, etc.) or (ii) I brought about a situation such that Taroo would drink only beer (and no whiskey, etc.), and a similar ambiguity exists in the interpretation of (35b).

- (35) a. ano ban watasi wa Taroo ni biiru sika nom-ase-na-katta.
 that night I TOP Taroo DAT beer except drink-CAUS-NEG-PAST
 ‘That night, I made/let Taroo drink only beer.’ *lit.* ‘... not drink except beer.’
- b. Rupan wa tesita ni hooseki sika nusum-ase-na-katta.
 Lupin TOP follower DAT jewelry except steal-CAUS-NEG-PAST
 ‘Lupin made/let his followers steal only the jewelry.’

In light of these observations, it is essential that any lexical account of causatives make clear how it can deal with such ambiguous scope assignments. Under the assumption that the causative is a single lexical entity, the problem posed by such examples is basically the problem of how to assign ‘word-internal’ scope to a quantified NP that appears external to

¹¹For example, *kare* does not serve as a bound variable: *kare* does not refer to the quantified subject NP in (i) and (ii).

- (i) ?*dono otoko_i mo kare_i no tomodati o hihan si-ta.
 which man also he GEN friend ACC criticism do-PAST
 ‘Every man_i criticized his_i friend.’
- (ii) *dono otoko_i mo [Masaru ga kare_i o hometa] koto ni odoroi-ta.
 which man also Masaru NOM he ACC praised COMP DAT be.surprised-PAST
 ‘Every man_i was surprised at the fact that Masaru praised him_i.’

Furthermore, as Takubo (1990) observes, *kare* can only refer to a person whose identity has been established in the speaker’s knowledge.

the lexical causative. The account must predict that a quantified argument of the causative verb can be interpreted as having narrow scope with respect to the causative operator, even though there is no syntactic constituent to serve as the basis of that particular scope assignment.

3 Background and Basics of the Analysis

3.1 Essentials of HPSG

Our general proposal for a lexical treatment of *-sase* causatives is compatible with a variety of lexicalist frameworks. The crucial ingredient we need is a theory of word formation that allows constraints to apply to the argument structures of both the causative verb as a whole and also the stem to which the causative suffix is added.¹² The conception of argument structure that we employ is based on essentially the same notion of SUBCAT lists as that used by Pollard and Sag (1987) and Gunji (1987). However, following recent work in HPSG,¹³ we distinguish argument structure (ARG-ST) from a word’s valence, which is specified in terms of the features SUBJECT (SUBJ), COMPLEMENTS (COMPS), and SPECIFIER (SPR). Canonically, the values of a word’s valence features ‘add up’ (via list concatenation [or the ‘append’ relation]) to the verb’s ARG-ST value, as illustrated for the English words in (36).¹⁴

(36) a. buys

$$\left[\begin{array}{ll} \text{HEAD} & \textit{verb}[\textit{fin}] \\ \text{SUBJ} & \langle \boxed{1}\text{NP}[\text{N}]_{3s} \rangle \\ \text{COMPS} & \langle \boxed{2}\text{NP} \rangle \\ \text{ARG-ST} & \langle \boxed{1}, \boxed{2} \rangle \end{array} \right]$$

b. picture

$$\left[\begin{array}{ll} \text{HEAD} & \textit{noun} \\ \text{SPR} & \langle \boxed{1}\textit{det} \rangle \\ \text{COMPS} & \langle \langle \boxed{2}\text{PP}[\textit{of}] \rangle \rangle \\ \text{ARG-ST} & \langle \boxed{1}, \boxed{2} \rangle \end{array} \right]$$

In this theory, it is the valence features (not ARG-ST) whose values are ‘cancelled off’ (in a Categorical Grammar-like manner) as a head projects a phrase. A lexical head combines with its complements and subject or specifier (if any) according to the lexically inherited specification, as shown in (37).

¹²The notion of argument structure draws from related work in many frameworks, for instance Kiparsky (1987), Rappaport and Levin (1988), Bresnan and Zaenen (1990), Grimshaw (1990), Alsina (1993), and Butt (1993). Our conception of argument structure is developed more fully in Manning and Sag (to appear). Let us merely note that in this work argument structure has the following three properties: (1) it is a syntactic construct that is crucially distinct from semantic structure (Manning 1994), but systematically related to it (Davis 1996); (2) it is associated only with *lexical signs*, not *phrases*; and (3) it is the locus of binding theory.

¹³Borsley (1989), Pollard and Sag (1994, chap.9), Miller and Sag (1997), Abeillé and Godard (1994).

¹⁴Here and throughout, we are ignoring the details of the feature geometry of HPSG signs, displaying only those features that are of direct relevance. We return below to the issue of argument conservation, i.e. the relation between the values of valence features and argument structure.

approach) while preserving the locality of information and lexical integrity of words within the syntax that is well-captured within the lexical rules approach. The first point means that all of stem, word and derivational types are organized into a hierarchy of types, each of which is associated with appropriate constraints. Extending the type hierarchy over derivational types and their result types more easily allows the various patterns of causatives and their linking patterns to be expressed. The second point implies that the formalism allows only a constrained correspondence between two stems, and hence entails a certain notion of locality. Only information specifically carried over from input to output by the rule is visible in the context where the causative stem occurs, and the syntax has no other access to the derivational history of a word.

That is, we assume that the basic lexical entry for the stem *buy* need stipulate only the information shown in (38):

$$(38) \textit{ buy: } \left[\begin{array}{l} \textit{v-stem} \ \& \ \textit{strict-trans} \\ \text{CONTENT} \quad \textit{buy-rel} \end{array} \right]$$

where *v(erb)-stem* and *strict-trans(itive)* are distinct types associated with the constraints illustrated in (39):

$$(39) \text{ a. } \textit{strict-trans: } \left[\text{ARG-ST} \quad \langle \text{NP}, \text{NP} \rangle \right]$$

$$\text{ b. } \textit{v-stem: } \left[\text{HEAD} \quad \textit{verb} \right]$$

Moreover, in the spirit of Wechsler (1995) and Davis (1996), we will assume that the projection of semantic roles to syntactic argument structure is mediated by general principles also formulated as constraints on lexical types. First, we assume, following Davis, that *buy-rel* is a subtype of *act(or)-und(ergoer)-rel*. This leads to the attributes ACTOR and UNDERGOER being appropriate for *buy-rel*, and this classification, together with inheritance of the constraints in (39), means that the stem *buy* inherits all the the information shown in (40):

$$(40) \textit{ buy: } \left[\begin{array}{l} \textit{strict-trans} \\ \text{HEAD} \quad \textit{verb} \\ \text{ARG-ST} \quad \langle \text{NP}, \text{NP} \rangle \\ \text{CONTENT} \quad \left[\begin{array}{l} \textit{buy-rel} \\ \text{ACTOR} \quad [] \\ \text{UNDERGOER} \quad [] \end{array} \right] \end{array} \right]$$

The classification of *buy-rel* as a subtype of *act-und-rel* is also the key to explaining its argument projection properties. Because of the general relation (a subsumption-preserving homomorphism) that Davis establishes between stem types and types of semantic relation, it follows that any stem like *buy* must obey the constraints established for superordinate stem types.

To see this, let us examine the case of *buy* a bit more closely. Davis posits stem types like those shown in (41).¹⁶

$$(41) \text{ a. } \textit{actor-stem}: \left[\begin{array}{l} \text{CONTENT} \quad \left[\begin{array}{l} \textit{act-rel} \\ \text{ACTOR} \quad i \end{array} \right] \\ \text{ARG-ST} \quad \langle \text{NP}_i, \dots \rangle \end{array} \right]$$

$$\text{ b. } \textit{undergoer-stem}: \left[\begin{array}{l} \text{CONTENT} \quad \left[\begin{array}{l} \textit{und-rel} \\ \text{UNDERGOER} \quad j \end{array} \right] \\ \text{ARG-ST} \quad \langle \dots \text{NP}_j, \dots \rangle \end{array} \right]$$

Because *buy-rel* is a subtype of *act-und-rel*, which in turn is a subtype of both *actor-rel* and *undergoer-rel*, the strong correspondence between stem types and relation types requires that the stem *buy* must also be a subtype of both stem types in (41). Thus the stem *buy* must also inherit the constraints associated with those types. Unifying the constraints in (41) with the information in (40), we derive the correct linking pattern for *buy*, as shown in (42).

$$(42) \textit{buy}: \left[\begin{array}{l} \textit{strict-trans} \\ \text{HEAD} \quad \textit{verb} \\ \text{ARG-ST} \quad \langle \text{NP}_i, \text{NP}_j \rangle \\ \text{CONTENT} \quad \left[\begin{array}{l} \textit{buy-rel} \\ \text{ACTOR} \quad i \\ \text{UNDERGOER} \quad j \end{array} \right] \end{array} \right]$$

The canonical relation between ARG-ST and VALENCE features is also determined by a general type constraint, namely the constraint on the type *stem*.

$$(43) \textit{stem}: \left[\begin{array}{l} \text{SUBJ} \quad \boxed{1} \\ \text{COMPS} \quad \text{compression}(\boxed{2}) \\ \text{ARG-ST} \quad \boxed{1} \oplus \boxed{2} \end{array} \right]$$

Here ‘ \oplus ’ designates the operation of list concatenation (or **append**). For the moment, we may assume that **compression** is just the identity function, and the constraints of this type just cause the ARG-ST to be the list concatenation of the SUBJ and COMPS lists (as illustrated earlier). An independent constraint guarantees that a stem’s SUBJ value is a singleton list. Thus because *strict-trans* is a subtype of *stem*, *buy* must inherit the information in (43) as well. Hence, in virtue of the system of lexical types and the associated type constraints, the minimal lexical entry for the stem *buy* given in (38) above is sufficient to guarantee that *buy* actually contains all the information in (44).

¹⁶Davis’s work follows a tradition pioneered in particular by Gawron and Wechsler, incorporating certain specific semantic analyses proposed by Pinker, and adapting ideas of Jackendoff. For an overview of the history of these ideas, see Davis (1996).

$$(44) \textit{buy}: \left[\begin{array}{l} \textit{strict-trans} \\ \text{HEAD} \quad \textit{verb} \\ \text{SUBJ} \quad \langle \boxed{1} \rangle \\ \text{COMPS} \quad \langle \boxed{2} \rangle \\ \text{ARG-ST} \quad \langle \boxed{1}\text{NP}_i, \boxed{2}\text{NP}_j \rangle \\ \text{CONTENT} \quad \left[\begin{array}{l} \textit{buy-rel} \\ \text{ACTOR} \quad i \\ \text{UNDERGOER} \quad j \end{array} \right] \end{array} \right]$$

This result is obtained in a principled, deductive fashion from constraints of considerable generality. In section 4, we will extend this treatment to include a lexical account of quantifier scoping as well.

3.3 Causative Stems

Causative stems bear a systematic phonological, syntactic and semantic relation to the verb stems from which they are formed. The information that must be specified within any analysis of Japanese causative stems is the following:

- (45) a. *-(s)ase* is suffixed in the PHONOLOGY,
 b. the stem's CONTENT is embedded as the EFFECT argument of the derived form's CONTENT, which is a ternary *cause-rel* relation,
 c. the derived form's argument structure contains a causer subject and a causee complement (inter alia)

Our intention is to account for these properties in terms of a single derivational type, *caus(ative)-drv*, the grammatical constraints particular to that type, and their interaction with constraints on other related lexical types. We posit only the following constraints as particular to the type *caus-drv*:¹⁷

$$(46) \textit{caus-drv}: \left[\begin{array}{l} \text{RESULT} \quad \left[\begin{array}{l} \textit{caus-stem} \\ \text{PHON} \quad \text{F}_{\textit{sase}}(\boxed{1}) \\ \text{CONT} \quad \left[\begin{array}{l} \textit{cause-rel} \\ \text{EFFECT} \quad \boxed{3} \end{array} \right] \end{array} \right] \\ \text{SOURCE} \quad \left[\begin{array}{l} \textit{v-stem} \\ \text{PHON} \quad \boxed{1} \\ \text{CONT} \quad \boxed{3} \end{array} \right] \end{array} \right]$$

First, let us consider the linking properties of causatives. The type *caus-rel* (like *buy-rel*) is a subtype of *act-und-rel*. Hence (by the same reasoning outlined in the previous section)

¹⁷The function $\text{F}_{\textit{sase}}(\text{X})$ yields $\text{X}+\textit{sase}$, if X is vowel-final, and $\text{X}+\textit{ase}$ otherwise.

the relation/stem correspondence ensures that *caus-stem* is a subtype of both *actor-stem* and *undergoer-stem*, which in turn entails that the first ARG-ST member is linked to the causer (ACTOR) and the second ARG-ST member to the causee (UNDERGOER), as shown in (47):

$$(47) \text{ } \textit{caus-stem}: \left[\begin{array}{ll} \text{PHON} & F_{\textit{sase}}(\boxed{1}) \\ \text{ARG-ST} & \langle \text{NP}_i, \text{NP}_j, \dots \rangle \\ & \left[\begin{array}{ll} \textit{cause-rel} & \\ \text{ACTOR} & i \\ \text{UNDERGOER} & j \\ \text{EFFECT} & \boxed{3} \end{array} \right] \\ \text{CONT} & \end{array} \right]$$

As for the rest of the causative stem’s ARG-ST, we will assume that this is a list consisting of just the ARG-ST value of the non-causative stem, itself a list. The causative’s ARG-ST value is thus a ‘nested’ list (a list that contains another list as a member), a fact that will play a crucial role in our account of constraints on binding.

On our analysis, causatives acquire such nested argument lists in virtue of the fact that *caus-drv* is a subtype of another type that we will call *complex-pred(icate)-drv*. A first version of the constraints on the type *complex-pred-drv* (in Japanese) are the following:¹⁸

$$(48) \text{ } \textit{complex-pred-drv}: \left[\begin{array}{ll} \text{RESULT} & \left[\text{ARG-ST} \left\langle \boxed{1}, \boxed{2}, \boxed{4} \langle \text{PRO}, \dots \rangle \right\rangle \right] \\ \text{SOURCE} & \left[\text{ARG-ST} \boxed{4} \right] \end{array} \right]$$

‘PRO’ here designates a special type of element that is associated with the subject of the basic stem. PRO is coindexed with some member of the (outer) ARG-ST list in accordance with fundamentally semantic principles similar to those outlined for English control constructions in Sag and Pollard (1991) (see Davis 1996). At least for Japanese causatives, though perhaps not for all instances of the type *comp-pred*, it is the second ARG-ST member (the causee) that is coindexed with PRO. Note that PRO is never an overt subject or complement.

Because of the list embedding in (48), we must modify our account of the linking relation between ARG-ST and VALENCE. This is where the function *compression* is needed. The idea is still that the SUBJ and COMPS lists add up to the argument structure, but we need to remove the embedded lists and PRO elements from the argument structure. Informally, what *compression* will do is flatten out embedded lists in the ARG-ST list, promoting their members to be on a par with the other list members and deleting embedded PROs in the process (hence the name *compression*).¹⁹

¹⁸We will later revise this to incorporate our account of lexicalized quantifier scoping.

¹⁹The function *compression* can be defined as follows (‘ \leftarrow ’ designates ‘only if’):

- (i) $\textit{compression}(\langle \rangle) = \langle \rangle$.
- (ii) $\textit{compression}(\langle \textit{PRO} | Y \rangle) = Z \leftarrow \textit{compression}(Y) = Z$.
- (iii) $\textit{compression}(\langle X | Y \rangle) = \langle X | Z \rangle \leftarrow X \text{ is a } \textit{synsem}, \textit{compression}(Y) = Z$.
- (iv) $\textit{compression}(\langle X | Y \rangle) = Z \leftarrow X \text{ is a } \textit{list}, \textit{compression}(X) = X', \textit{compression}(Y) = Y', \textit{append}(X', Y') = Z$.

With this revision in place, we can now see how the constraints illustrated in this section and the previous one interact to guarantee that the causative formed from the stem *kaw-* ‘buy’ has all the properties illustrated in (49):²⁰

(49) *kawase-* ‘cause to buy’

<i>caus-stem</i>															
HEAD	<i>verb</i>														
SUBJ	$\langle \boxed{1}\text{NP}[\text{N}]_i \rangle$														
COMPS	$\langle \boxed{2}\text{NP}[\text{D}]_j, \boxed{3}\text{NP}[\text{A}]_k \rangle$														
CONT	<table style="border-collapse: collapse; margin: 0 auto;"> <tr> <td colspan="2" style="padding: 5px 0;"><i>cause-rel</i></td> </tr> <tr> <td style="padding: 5px 0;">ACTOR</td> <td style="padding: 5px 0;"><i>i</i></td> </tr> <tr> <td style="padding: 5px 0;">UNDERGOER</td> <td style="padding: 5px 0;"><i>j</i></td> </tr> <tr> <td style="padding: 5px 0; vertical-align: middle;">EFFECT</td> <td style="border-left: 1px solid black; border-right: 1px solid black; padding-left: 10px;"> <table style="border-collapse: collapse; margin: 0 auto;"> <tr> <td colspan="2" style="padding: 5px 0;"><i>buy-rel</i></td> </tr> <tr> <td style="padding: 5px 0;">ACTOR</td> <td style="padding: 5px 0;"><i>j</i></td> </tr> <tr> <td style="padding: 5px 0;">UNDERGOER</td> <td style="padding: 5px 0;"><i>k</i></td> </tr> </table> </td> </tr> </table>	<i>cause-rel</i>		ACTOR	<i>i</i>	UNDERGOER	<i>j</i>	EFFECT	<table style="border-collapse: collapse; margin: 0 auto;"> <tr> <td colspan="2" style="padding: 5px 0;"><i>buy-rel</i></td> </tr> <tr> <td style="padding: 5px 0;">ACTOR</td> <td style="padding: 5px 0;"><i>j</i></td> </tr> <tr> <td style="padding: 5px 0;">UNDERGOER</td> <td style="padding: 5px 0;"><i>k</i></td> </tr> </table>	<i>buy-rel</i>		ACTOR	<i>j</i>	UNDERGOER	<i>k</i>
<i>cause-rel</i>															
ACTOR	<i>i</i>														
UNDERGOER	<i>j</i>														
EFFECT	<table style="border-collapse: collapse; margin: 0 auto;"> <tr> <td colspan="2" style="padding: 5px 0;"><i>buy-rel</i></td> </tr> <tr> <td style="padding: 5px 0;">ACTOR</td> <td style="padding: 5px 0;"><i>j</i></td> </tr> <tr> <td style="padding: 5px 0;">UNDERGOER</td> <td style="padding: 5px 0;"><i>k</i></td> </tr> </table>	<i>buy-rel</i>		ACTOR	<i>j</i>	UNDERGOER	<i>k</i>								
<i>buy-rel</i>															
ACTOR	<i>j</i>														
UNDERGOER	<i>k</i>														
ARG-ST	$\langle \boxed{1}_i, \boxed{2}_j, \langle \text{PRO}_j, \boxed{3}_k \rangle \rangle$														

Stems like the one in (49) may be used as the basis for building the inflected words that serve as syntactic heads. Inflection does not alter the valence, argument structure, or semantic content in relevant ways, however. Thus, the information sketched in (49) corresponds in all relevant respects to the information borne by a causative verb when it functions as the lexical head of a syntactic phrase, combining with its complements according to the same principles that govern the combination of noncausative heads. Let us now see how this analysis can be applied first to adjuncts and the alleged coordination facts, and then to issues of binding and scope.

4 Analysis

4.1 Adjunct scope and “Coordination”

As we have seen, the verbal ending *-te* marks phrases that are better analyzed as adverbials, not conjuncts. We provide a uniform treatment of scope that covers the interpretation of adverbs, putative coordination, and a number of related issues. The analysis we will sketch, if nothing more is said, entails that adverbs will be added to valence lists freely and hence, given our assumptions about scrambling, freely ordered among other complements.

The essence of our proposal is a ‘zero derivation’ type that adds an adjunct onto a verb stem’s ARG-ST list (and hence onto its COMPS list). We couch this proposal in terms of

²⁰We leave a number of matters unresolved here. For case assignment, we assume general case assigning rules for Japanese (which may make reference to structural, lexical, or semantic features), but do not attempt to develop them here.

the derivational type $a(dverb-)t(ype-)r(aising)-drv$ sketched in (50), which encodes a kind of *type-raising*, a function-argument reversal commonly utilized within categorial grammar.²¹

(50) *atr-drv*

$$\left[\begin{array}{l} \text{RESULT} \\ \text{SOURCE} \end{array} \left[\begin{array}{l} \textit{atr-stem} \\ \text{PHON} \quad \boxed{4} \\ \text{ARG-ST} \quad \boxed{1} \oplus \langle \text{ADV}[\text{CONT } \boxed{3}] \rangle \\ \text{CONTENT} \quad \boxed{3} \left[\text{ARG} \quad \boxed{2} \right] \\ \text{PHON} \quad \boxed{4} \\ \text{ARG-ST} \quad \boxed{1} \\ \text{CONTENT} \quad \boxed{2} \end{array} \right] \right]$$

Stems resulting from this type have a semantic content that is based on the adverb complement it will combine with, at the same time making the content of the SOURCE value (the stem from which the *atr-stem* is ‘derived’) the argument of that adverbial. Since *atr-stem* is a subtype of *canon-stem* (see above), it also follows that the adverb is the last element of the *atr-stem*’s COMPS list.

Note that the definition of *compression* given in fn. 19 interacts with the constraints in (50) to ensure that the SUBJ and COMPS lists of a causative stem are correctly treated. For instance (51) shows the type that results when the basic verb stem *kaw-* ‘buy’ is first causativized and then undergoes adverb type raising (hence giving the selected adverb wide scope):

(51)

$$\left[\begin{array}{l} \textit{atr-stem} \\ \text{PHON} \quad \textit{kaw-ase} \\ \text{SUBJ} \quad \langle \boxed{8}\text{NP}[\text{N}]_k \rangle \\ \text{COMPS} \quad \langle \boxed{9}\text{NP}[\text{D}]_i, \boxed{2}\text{NP}[\text{A}]_j, \boxed{3}\text{ADV}[\text{CONT } \boxed{5}] \rangle \\ \text{ARG-ST} \quad \langle \boxed{8}, \boxed{9}, \langle \text{PRO}_i, \boxed{2} \rangle, \boxed{3} \rangle \\ \text{CONTENT} \quad \boxed{5} \left[\begin{array}{l} \textit{adverb-rel} \\ \text{ARG} \left[\begin{array}{l} \textit{cause-rel} \\ \text{ACTOR} \quad k \\ \text{UNDERGOER} \quad i \\ \textit{buy-rel} \\ \text{ACTOR} \quad i \\ \text{UNDERGOER} \quad j \end{array} \right] \end{array} \right] \end{array} \right]$$

²¹Our analysis differs from categorial analyses in that it employs a highly restricted, lexically-governed version of type raising. Its work is done before other arguments are combined with the raised functor. Nonetheless, all uses of our rule correspond to theorems of the Lambek calculus. Similar proposals for adverbial type raising in HPSG are made for French by Abeillé and Godard (1994), for Dutch by van Noord and Bouma (1994), and for English by Kim and Sag (1995).

But of course it is the possibility of the the adverb modifying within the scope of *cause-rel* that is more challenging for a lexicalist theory. So consider again the conjunctive adverbial in (52).

- (52) Naomi wa hurui kutu o sute-te atarasii kutu o kat-ta.
 Naomi TOP old shoes ACC throw-GER new shoes ACC buy-PAST
 ‘Naomi threw away her old shoes and bought new ones.’

The canonical stem *kaw*₁ discussed in the previous section gives rise through *atr-drv* to a phonologically indistinguishable counterpart *kaw*₂ of type *atr-stem* that must combine with an adverbial complement, as sketched in (53).

- (53) *kaw*₂:
$$\left[\begin{array}{l} \textit{atr-stem} \\ \text{PHON} \quad \textit{kaw} \\ \text{SUBJ} \quad \langle \boxed{1}\text{NP}[\text{N}]_i \rangle \\ \text{COMPS} \quad \langle \boxed{2}\text{NP}[\text{A}]_j, \boxed{3}\text{ADV}[\text{CONT } \boxed{5}] \rangle \\ \text{ARG-ST} \quad \langle \boxed{1}, \boxed{2}, \boxed{3} \rangle \\ \\ \text{CONTENT} \quad \boxed{5} \left[\begin{array}{l} \textit{adverb-rel} \\ \\ \text{ARG} \left[\begin{array}{l} \textit{buy-rel} \\ \text{ACTOR} \quad i \\ \text{UNDERGOER} \quad j \end{array} \right] \end{array} \right] \end{array} \right]$$

It is this stem that gives rise to the inflected form *kat-ta* that occurs in (52).

*kaw*₂ can also give rise via *caus-drv* to a causative stem, as shown in (54):

- (54)
$$\left[\begin{array}{l} \textit{caus-stem} \\ \text{PHON} \quad \textit{kaw-ase} \\ \text{SUBJ} \quad \langle \boxed{8}\text{NP}[\text{N}]_k \rangle \\ \text{COMPS} \quad \langle \boxed{9}\text{NP}[\text{D}]_i, \boxed{2}\text{NP}[\text{A}]_j, \boxed{3}\text{ADV}[\text{CONT } \boxed{5}] \rangle \\ \text{ARG-ST} \quad \langle \boxed{8}, \boxed{9}, \langle \text{PRO}_i, \boxed{2}, \boxed{3} \rangle \rangle \\ \\ \text{CONTENT} \left[\begin{array}{l} \textit{cause-rel} \\ \text{ACTOR} \quad k \\ \text{UNDERGOER} \quad i \\ \\ \text{EFFECT} \quad \boxed{5} \left[\begin{array}{l} \textit{adverb-rel} \\ \\ \text{ARG} \left[\begin{array}{l} \textit{buy-rel} \\ \text{ACTOR} \quad i \\ \text{UNDERGOER} \quad j \end{array} \right] \end{array} \right] \end{array} \right] \end{array} \right]$$

And it is tensed verbs formed from this stem that are the basis for the narrow scope reading of causative structures like (55), as illustrated in (56).

- (55) Ken wa Naomi ni hurui kutu o sute-te atarasii kutu o kaw-ase-ta.
 Ken TOP Naomi DAT old shoes ACC throw-GER new shoes ACC buy-CAUS-PAST
 ‘Ken made Naomi throw away her old shoes and buy new ones.’

(56)

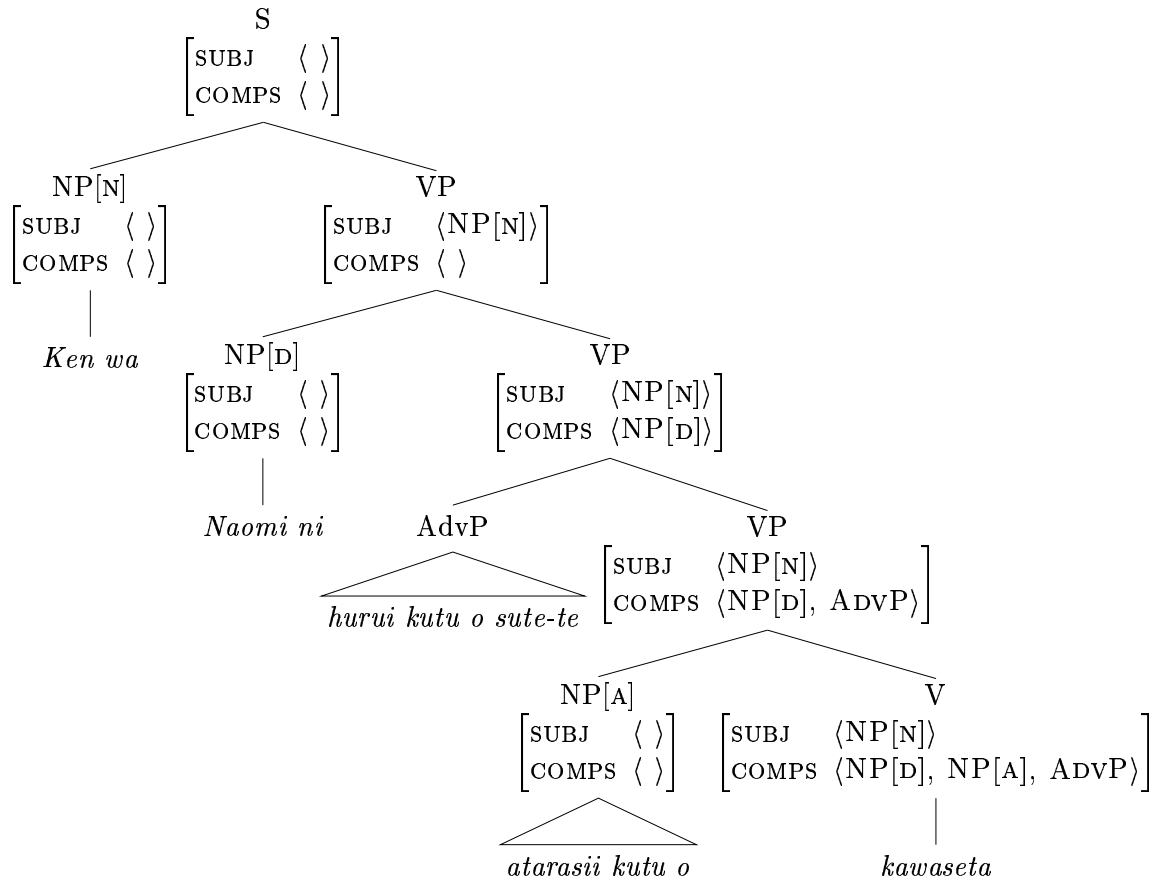

Note that the adverbial phrase in this example appears higher in the tree than the causative verb, but nonetheless modifies only the verbal stem *kaw*. Given that the modification relations are fixed by the lexical entries and the phrases they project, the same interpretation results from a scrambled example such as (57):

- (57) Ken wa Naomi ni atarasii kutu o [hurui kutu o sute-te] kaw-ase-ta.
 Ken TOP Naomi DAT new shoes ACC old shoes ACC throw-GER buy-CAUS-PAST
 ‘Ken made Naomi throw away old shoes and buy new shoes.’

Allowing type-raising predicates to place adverbs on their ARG-ST list in this way thus provides a straightforward account of both adverbial scope possibilities, and of the ability of *-te* phrases to scramble.

4.2 Binding Theory

4.2.1 Reflexives

The HPSG binding theory is based on hierarchical argument structure rather than constituent structure. As Pollard and Sag (1992, 1994) demonstrate, this approach to binding provides an immediate solution to a variety of problems facing accounts of English binding stated purely in terms of constituency-based notions such as c-command. Our account of

binding in Japanese is based on principles identical to those posited for English by Pollard and Sag, augmented by a new principle for long distance anaphors, such as Japanese *zibun*, identical to that proposed for Mandarin by Xue, Pollard and Sag (1994). These principles are stated informally in (58).

(58) HPSG Binding Theory:

Principle A. A locally o-commanded anaphor must be locally o-bound.

Principle B. A personal pronoun must be locally o-free.

Principle C. A non-pronoun must be o-free.

Principle Z. A long distance anaphor must be o-bound.

The effect of these principles is to require an anaphor to be coindexed with a less oblique ARG-ST member, if there *is* such a less oblique coargument. Otherwise, anaphors are free (subject to various discourse and processing considerations) to refer to appropriate elements in the discourse context.

The Japanese reflexive *zibun* is clearly long distance, and hence properly governed by Principle Z. However, as we saw earlier, its antecedence is usually restricted to subjects. Manning (1994, 1996) argues that the correct constraint in these cases is the principle in (59):

(59) A-subject principle: Some anaphors must be bound by an entity that is first on some ARG-ST list.

Kitagawa (1986), citing unpublished work by K. Kurata, has argued that the expressions *mizukara* ‘self’ and *zibun-zisin* ‘self’ are true anaphors that obey Principle A. However, there are reasons to be skeptical of this claim. There are numerous counterexamples to the putative generalization that *mizukara* ‘self’ and *zibun-zisin* ‘self’ must have a local binder, as illustrated by the following examples:

(60) a. *Zibun-zisin_i ga hihan s-are-ta koto ga Taroo_i o nayamase-te iru.*
 self NOM criticism do-PASS-PAST COMP NOM Taroo ACC bother-PROG-PRES
 (lit.) ‘The fact that self was criticized bothers Taroo.’

b. *kono hoosiki no moto-de wa, wakai toki-ni zibun-zisin_i ga*
 this system GEN under TOP young when self NOM
siharat-ta kingaku ga yokinsya_i no nenkin ni tuika deki-ru.
 pay-PAST amount NOM depositor GEN pension to add can-PRES
 ‘Under this system, the amount that a depositor paid at his younger age can be added to his pension plans.’

These might be explained away as ‘exempt’ anaphors, that is as anaphors that, because they lack a local o-commanding element (nothing outranks a subject in an ARG-ST list), are not constrained to be locally o-bound. This approach is possible in the HPSG binding theory (see the formulation of Principle A given above), but not in other binding theories we are familiar with. However we doubt that this kind of analysis is sufficient to explain examples like the following, where *zibun-zishin* is locally o-commanded, but not locally o-bound.

- (61) a. Taroo_i wa tomodati_j ni zibun-zisin_{i/j} ni tugoo no ii
 Taroo TOP friend DAT self DAT circumstances GEN good
 syoogen o s-ase-ta.
 testimony ACC do-CAUS-PAST
 ‘Taroo_i made his friend_j give evidence convenient for him_{i/j}.’
- b. Tanaka-kyoozyu_i wa [gakusei ga gakkoo-tookyoku dake de-naku zibun-zisin_i
 Tanaka-professor TOP student NOM school-authorities only be-NEG self
 ni mo sinrai o oi-te i-nakat-ta] noni gakuzen to si-ta.
 on even reliance ACC place-PROG-NEG-PAST since shocked COMP do-PAST
 ‘Prof. Tanaka_i got shocked at the fact that the students didn’t rely on not only the
 school authorities but also him_i.’

Moreover, as suggested to us by Takao Gunji (personal communication, July 1993) it may simply be the emphatic nature of these expressions that makes them tend to prefer a local antecedent (at least in simple examples) without their actually being subject to Principle A. This line of reasoning, quite like that followed by Iida (1992) in her account of *zibun*-binding, seems more likely to provide a systematic account of the entire range of observations about *zibun-zishin*-binding.

Thus we will tentatively regard both *zibun* and *zibun-zisin* as subject to Principle Z and the A-subject Principle. We may now examine the predictions made by our lexical analysis of causatives. Recall that in this analysis, the ARG-ST list of the lower verb is embedded in the causative verb’s ARG-ST list, as illustrated in (62).

- (62)
$$\left[\begin{array}{l} \textit{caus-stem} \\ \text{PHON} \quad \textit{hihan sase} \\ \text{SUBJ} \quad \langle \text{I} \rangle \\ \text{COMPS} \quad \langle \text{2}, \text{3} \rangle \\ \text{ARG-ST} \quad \langle \text{I} \text{NP}_i, \text{2} \text{NP}_j, \langle \text{PRO}_j, \text{3} \text{NP}_k \rangle \rangle \\ \\ \text{CONT} \quad \left[\begin{array}{l} \textit{cause-rel} \\ \text{ACTOR} \quad i \\ \text{UNDERGOER} \quad j \\ \\ \text{EFFECT} \quad \left[\begin{array}{l} \textit{criticize-rel} \\ \text{ACTOR} \quad j \\ \text{UNDERGOER} \quad k \end{array} \right] \end{array} \right] \end{array} \right]$$

In (62), the lower object 3 appears on the embedded ARG-ST list of the verb. Thus according to the binding theory in (58), if the lower object is a true anaphor, then it is locally o-commanded and can be locally o-bound by only one element – PRO (coindexed with the causee). This prediction contradicts the claims made by Kitagawa (1986) and Yatabe (1993) about the ambiguity of examples like (63).

- (63) Taroo_i ga Ziroo_j ni aete zibun-zisin_{i/j} o hihan s-ase-ta.
 Taroo NOM Ziroo DAT purposefully self ACC criticism do-CAUS-PAST
 ‘Taroo_i purposefully made Ziroo_j criticize himself_{i/j}.’ (Kitagawa 1986:(92))

Both of these researchers assume that the grammar of causatives must be reconciled with this ambiguity by somehow providing two domains in which the anaphor can be bound.

However, on the assumption that *zibun-zisin* is not a true anaphor, but a long distance anaphor subject to Principle Z and the A-subject constraint (requiring that the binder of *zibun-zisin* be the first element of some argument structure list), the ambiguity of (63) is unproblematic. On this theory *zibun-zisin* is free to be bound by any o-commanding a-subject, and so we predict that it can be bound by either of the higher a-subjects, *Taroo* or *Ziroo*.

4.2.2 Pronouns

Now let us consider again the pronominal coreference facts shown in (64).

- (64) Taroo_i wa Ziroo_j ni kare o / \emptyset _{i/*j} bengo s-ase-ta.
 Taroo TOP Ziroo DAT him ACC/pro defense do-CAUS-PAST
 ‘Taroo_i made Ziroo_j defend him_{i/*j}.’

The zero pronoun, or *kare*, in the lower object position allows the surface subject, but not the lower subject (the causee), as its antecedent.

Here, again, we find confirmation of our nested argument structure analysis. The observed facts follow immediately from the nested ARG-ST analysis and the assumption that missing arguments and *kare* are both pronominals. Considering again (62), we see that coindexation of the subject and the lower object is possible, because there is no ARG-ST list where both elements occur. However, the lower object cannot be coindexed with the causee, because the causee shares an index with the lower subject, hence indexing the lower object in this way would make the lower object locally o-bound, in violation of Principle B.

Hence, by assuming simply that Japanese has pronominal arguments, we can use the very same binding principles that have been applied to English and other languages. Principle B rules out coreference between the lower object and the causee, but nothing blocks coreference between the lower object and the subject because the surface subject isn’t on the embedded ARG-ST list.

4.2.3 Adverbial *-nagara* clauses

This understanding of a-subjects, together with the preceding account of adjuncts is also the basis of the treatment we would give of adverbial *-nagara* clauses, which can be placed freely in a sentence like other adverbials, and which can be controlled by any a-subject, but not other noun phrases, as is shown for causatives in (65):

- (65) Taroo wa kodomotati ni utai-nagara tegami o kak-ase-ta.
 Taroo TOP children DAT sing-while letter ACC write-CAUS-PAST
 ‘Taroo_i made the children_j write a letter while he_i/they_j sang.’

4.3 Quantifier Scope

As noted in section 2.3.5, quantified NPs pose a problem similar to that of adverbs: A quantified NP functioning as the lower object of a causative verb form can take intermediate

scope, i.e. although external to the lexical causative, it can scope over the verb stem, but within the scope of the causative operator, as illustrated in (66).

- (66) Tanaka-sensei ga gakusei ni sansatu hon o sirabe-sase-ta.
 Prof. Tanaka NOM student DAT three book ACC check-CAUS-PAST
 ‘Prof. Tanaka made [the student check three books].’

In order to deal with this matter, we must first enter into a slight digression about the treatment of quantifier scope in HPSG.

4.3.1 Quantifier scope in HPSG

The theory of quantifier scope presented in chapter 8 of Pollard and Sag 1994 (P&S) is based on the technique of quantifier storage pioneered in Cooper (1983). ‘Cooper storage’ is a method allowing a variable to go proxy for a quantifier’s contribution to the content of a sentence, while the quantifier which binds that variable is placed in a ‘store’. Stored quantifiers are gathered up from the daughters of a phrase and passed up to successively higher levels of structure until an appropriate scope assignment locus is reached. There quantifier(s) may be retrieved from storage and integrated into the meaning, receiving a wide scope interpretation, as illustrated in (67) in terms of the HPSG features QS(TORE) and CONT(ENT):

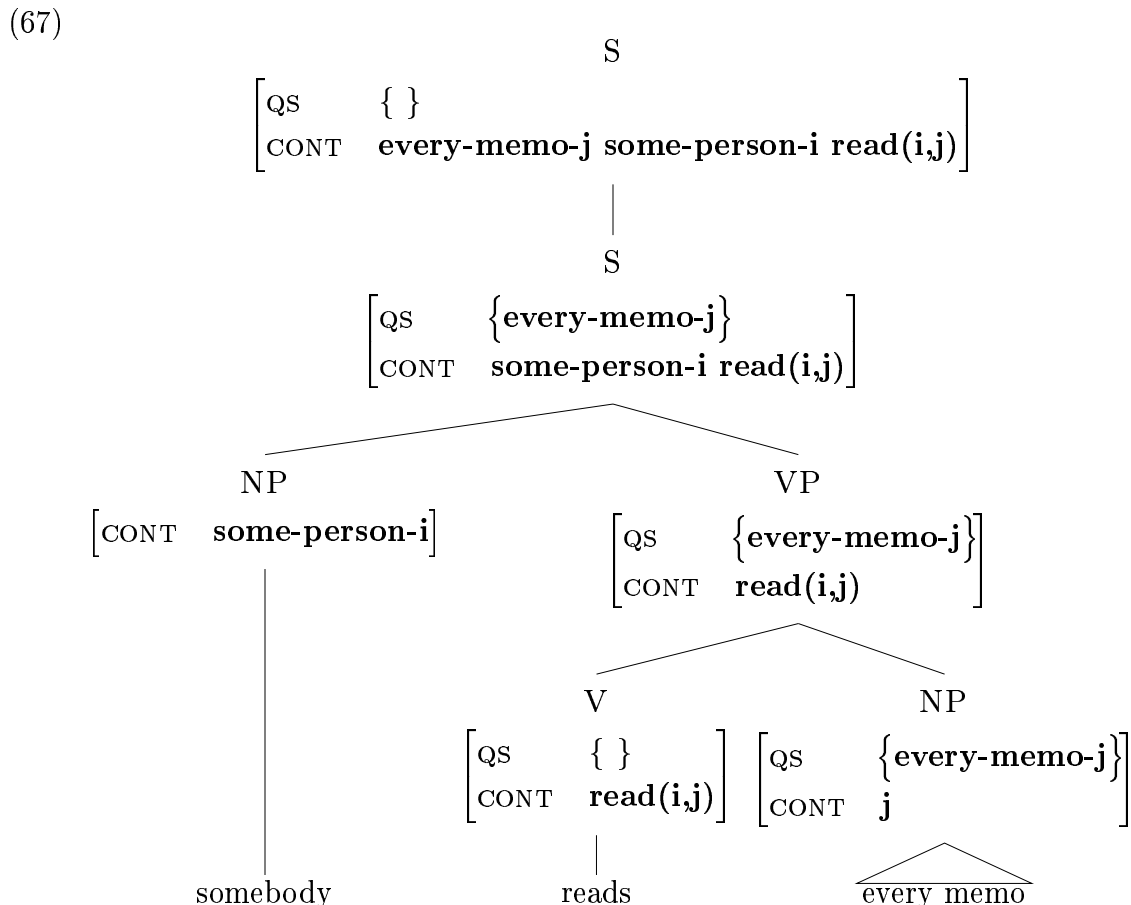

On P&S’s version of Cooper’s theory, CONTENT is specified for two attributes: QUANTS (QUANTIFIERS) and NUC(LEUS), the former taking a list of generalized quantifiers as its value, the latter taking what we have here treated as relations. On their theory, all quantifiers ‘start out’ in storage, and retrieval (removal of some set of quantifiers from the QSTORE set and appending of some ordering of the removed set to the head’s QUANTS list) is allowed at higher levels of structure, subject to various constraints. This means that the scope assigned to a quantifier can in principle be any higher semantic domain, i.e. any semantic domain containing the semantics of the minimal clause containing the quantified NP. P&S’s version also differs from Cooper’s in eliminating the non-branching structure (the ‘S-over-S’ structure in (67)) associated with retrieval.

However, the theory presented by P&S has at least one serious defect²² – its failure to provide for the possibility that in raising or extraction constructions, a quantifier may have scope corresponding to a lower syntactic position. As is well known, a sentence like (68), for example, allows a ‘de dicto’ reading where the matrix subject takes narrow scope with respect to *seems*:

- (68) A unicorn seems to be approaching.
 ‘It seems that there is a unicorn approaching.’

In recent work, Pollard and Yoo (forthcoming) suggest the beginnings of a solution to this problem. First, they propose to make QSTORE a feature of *local* objects, rather than a feature of the highest level of grammatical structure (the *sign*), as P&S proposed. This revision has the consequence that within raising and extraction constructions, the stored quantifiers are identified. That is, the QSTORE value of the subject of *seems* in a cascaded raising structure like (68) is also the QSTORE value of the (unexpressed) subject of *to*, the QSTORE value of the subject of *be*, and the QSTORE value of the subject of the verb *approaching*. Thus if the NP *a unicorn* in (68) has an existential quantifier in its QSTORE, so does the SUBJ value of the lowest verb in (68) – the verb that assigns a semantic role to the index bound by that quantifier.

Pollard and Yoo propose to change the way storage works, so that unscoped quantifiers are passed up to the mother in a headed structure not from all the daughters (as in Cooper’s account or that of P&S), but only from the semantic head daughter. To achieve this, they let the QSTORE value of a verb V be the set union of the QSTORE values of V’s ARG-ST members (at least those ARG-ST members that are assigned a role in the CONTENT value of V). We illustrate the effect of their proposal in terms of the Quantifier Amalgamation Constraint (69a), which is formulated in terms of the *merge-quants* relation defined in (69b).²³

- (69) a. Quantifier Amalgamation Constraint (preliminary):

$$\text{word: } \left[\begin{array}{ll} \text{ARG-ST} & \sqcup \\ \text{QS} & \text{merge-quants}(\sqcup) \end{array} \right]$$

²²Exactly the same defect as Montague’s (1974) ‘proper treatment of quantification’, incidentally. We thank Bob Carpenter for pointing out some of the problems in the P&S theory of quantification.

²³ \sqcup here designates the relation of disjoint set union, which is defined exactly like familiar set union, except that its arguments must be disjoint sets (i.e. they must have an empty intersection). We will modify the definition of the Quantifier Amalgamation Constraint below.

$$b. \text{merge-quants}(\langle [QS \ 1], \dots, [QS \ n] \rangle) = 1 \uplus \dots \uplus n$$

On this approach, the QSTORE of the verb in (70) is nonempty and may be passed up the tree from head-daughter to mother as sketched in (70).

(70)

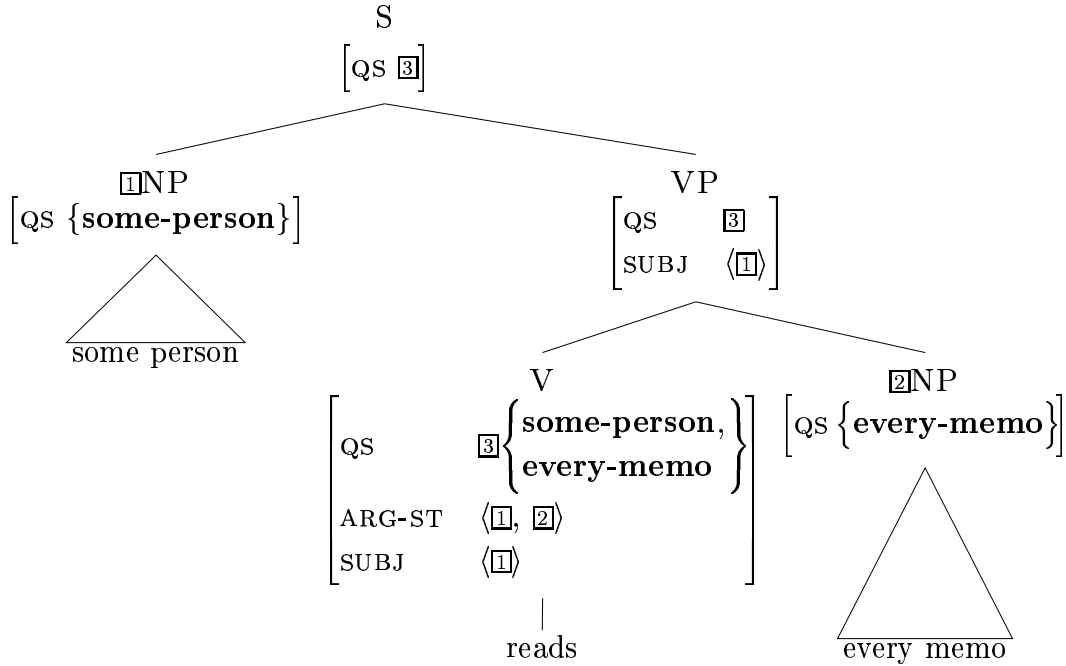

Let us ignore adjuncts for present purposes, considering only the case where the syntactic head and semantic head are the same, as in a structure like (70). S-level retrieval of stored quantifiers is done in accordance with the constraint sketched in (71):²⁴

(71) **Pollard/Yoo Quantifier Retrieval:**

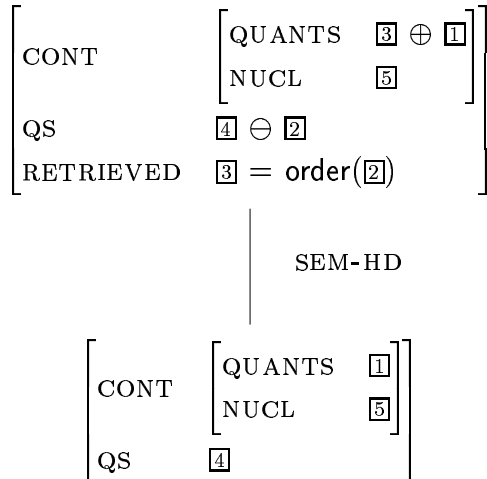

²⁴We use \ominus to designate a relation of contained set difference: if Σ_2 is a subset of Σ_1 , then $\Sigma_1 \ominus \Sigma_2$ is the standard set difference of Σ_1 with respect to Σ_2 ; otherwise, the contained set difference is not defined. Note also that up until now we have been showing the value of $\text{CONT}(\text{ENT})$ as simply the $\text{NUCL}(\text{EUS})$ value which excludes the effect of quantification, but in the semantic theory of HPSG, a clausal CONT has both a nucleus (NUCL) and a list of the quantifiers scoped at that node (QUANTS), as in the signs in this section.

And if we now reconsider the tree in (70) in light of the retrieval scheme sketched in (71), we can see the possibility of S-level quantifier retrieval of the sort sketched in (72):

(72)

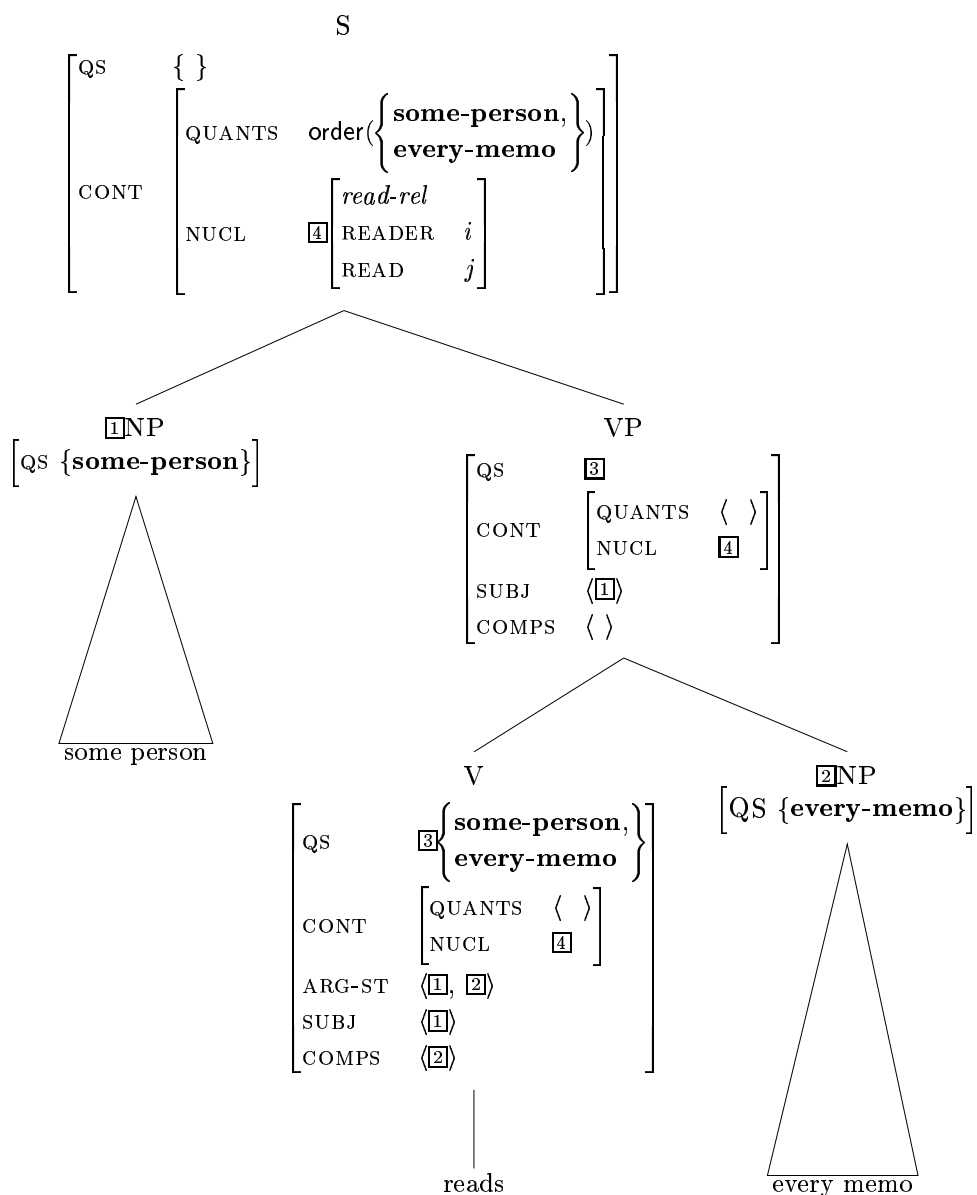

This correctly allows for both possible scopings for (72). It also assigns to (68) a reading where the subject has narrow scope with respect to *seems*, because QSTORE is now part of LOCAL and hence the SUBJ value of *seems* is the SUBJ value of *to* and *be* and hence is the SUBJ value (and first ARG-ST member) of *approaching*, which collects its own QSTORE value from the QSTORE values of its arguments. Thus the QSTORE of *approaching* in (68) contains **a-unicorn** and that quantifier can be retrieved from storage anywhere in the tree higher than *approaching*. Retrieval at the VP node dominating just *approaching* will produce the scoping of **a-unicorn** inside the scope of *seems*.

A potential problem with this approach, however, is that it lets retrieval happen in too many places. Unless one stipulates further constraints, this system (like the one in P&S)

produces spurious analyses of every available reading. For example, allowing both S and VP retrieval in structures like (72) produces each possible scoping in three different ways (each retrieval order at one node, or one quantifier retrieved at each node).

4.3.2 Lexicalizing quantifier scoping

The adaptation of the Pollard and Yoo analysis that we propose to solve the scope problems discussed in section 2.3.5 will at the same time eliminate this redundancy in the Pollard/Yoo system. We propose to let retrieval and scope assignment be entirely lexical in nature. By stating lexical constraints to the effect that a word's QUANTS value is an ordering of some set subtracted from the union of the QSTORE values of the verb's arguments, it is possible in fact to eliminate phrasal retrieval and the feature RETRIEVED entirely. A lexical head passes up in its QSTORE value the quantifiers from its arguments which are not already scoped in its QUANTS value, or earlier retrieved in its QRETR value. These unscoped quantifiers are thus passed up into the QSTORE value of the phrase projected by the lexical head. At this point, they are seen, and possibly retrieved by the head of the next higher syntactic domain.

This proposal, similar in certain ways to lexical type raising, involves modifying the Quantifier Amalgamation Constraint as follows:²⁵

(73) Quantifier Amalgamation Constraint (revised):

$$stem: \left[\begin{array}{ll} \text{ARG-ST} & \boxed{1} \\ \text{QS} & \text{merge-quals}(\text{toplevel}(\boxed{1})) \uplus \boxed{2} \ominus \boxed{3} \\ \text{NEW-QS} & \boxed{2} \\ \text{CONT} & [\text{QUANTS} \quad \text{order}(\boxed{3})] \end{array} \right]$$

The importance of the shift from *word* to *stem*, and the need to introduce a NEW-QS(TORE) attribute will be discussed in a moment. For the moment, one can assume that the value of NEW-QS is always the empty set. Now, first, note that in consequence of (73) the word *reads* (formed without relevant changes from the stem *read*) must be constrained along the lines sketched in (74).

²⁵The function `toplevel` returns just the unembedded members of an ARG-ST list. In other words, except for cases of nested ARG-ST lists formed by complex predicates, it will also act as an identity function. It can be defined as follows:

- (i) `toplevel(⟨ ⟩) = ⟨ ⟩`.
- (ii) `toplevel(⟨X|Y⟩) = ⟨X|Z⟩` ← *X* is a *synsem*, `toplevel(Y) = Z`.
- (iii) `toplevel(⟨X|Y⟩) = Z` ← *X* is a *list*, `toplevel(Y) = Z`

$$(74) \left[\begin{array}{l} \textit{word} \\ \text{PHON} \quad \textit{reads} \\ \text{ARG-ST} \quad \langle \text{NP}_i[\text{QS } \boxed{1}], \text{NP}_j[\text{QS } \boxed{2}] \rangle \\ \text{QS} \quad (\boxed{1} \uplus \boxed{2}) \ominus \boxed{3} \\ \text{CONT} \quad \left[\begin{array}{l} \text{QUANTS} \quad \text{order}(\boxed{3}) \\ \text{NUCL} \quad \left[\begin{array}{l} \textit{read-rel} \\ \text{ACTOR} \quad i \\ \text{UNDERGOER} \quad j \end{array} \right] \end{array} \right] \end{array} \right]$$

Other aspects of the Pollard/Yoo theory remain unchanged. Thus, each lexical head gets a chance to scope the quantifiers of its role-assigned arguments, and those quantifiers from arguments that are not scoped remain in the verb’s QSTORE to be passed up to higher levels of structure. There are exactly as many scope assignment points in a sentence as there are lexical heads. And since there is no structure-based retrieval, a sentence like (68) has no spurious semantic derivations. The constraints that are part of the lexical entry of the word *reads* simply allow two readings (corresponding to the two distinct orderings of the quantifiers on the verb’s QUANTS list). Note finally that this modification of the Pollard/Yoo theory still produces the correct two readings for *A unicorn seems to be approaching*, allowing *seems* or *approaching* to assign scope to **a-unicorn**.²⁶

4.3.3 Quantifier scope with morphological causatives

Let us now return to our analysis of causatives. We have already modified the Quantifier Amalgamation Constraint as in (73). In consequence of this modification, the verb stem *sirabe* ‘check’ must inherit all the constraints shown in (75):

$$(75) \left[\begin{array}{l} \textit{v-stem} \\ \text{PHON} \quad \textit{sirabe} \\ \text{ARG-ST} \quad \langle \text{NP}_j[\text{QS } \boxed{1}], \text{NP}_k[\text{QS } \boxed{2}] \rangle \\ \text{QS} \quad (\boxed{1} \uplus \boxed{2}) \ominus \boxed{3} \\ \text{NEW-QS} \quad \{ \} \\ \text{CONT} \quad \left[\begin{array}{l} \text{QUANTS} \quad \text{order}(\boxed{3}) \\ \text{NUCL} \quad \left[\begin{array}{l} \textit{check-rel} \\ \text{ACTOR} \quad j \\ \text{UNDERGOER} \quad k \end{array} \right] \end{array} \right] \end{array} \right]$$

²⁶In order to eliminate all spurious ambiguity in infinitival structures, we must state some further constraint ensuring that semantically vacuous raising verbs like *to* and *be* do not assign scope lexically. This is easily formulated as a lexical constraint requiring that elements like *to* and *be* identify their CONTENT value with that of their complement (lexicalizing one part of a constraint proposed by Pollard and Yoo).

The constraints specified in (75) say simply (i) that the QUANTS value of the stem’s CONTENT is an ordering of some subset of the argument’s QSTORE values and (ii) that those quantifiers not in QUANTS are in the stem’s QSTORE value.

The lexical retrieval for a complex predicate is similar, but it must take into account the possibility that the stem from which it is formed may have already assigned scope to some but not necessarily all of the quantifiers from the embedded argument structure. This is where the attribute NEW-QS comes in. We will say that for most basic stem types, including verb stems, the value of NEW-QS is the empty set. But for certain derived stem types such as those licensed by *complex-pred-drv*, the value of NEW-QS will be the set of quantifiers that were not yet scoped in the SOURCE stem from which they were built. This will be achieved by the following revision to the constraints on the type *complex-pred-drv*.²⁷

$$(76) \text{ complex-pred-drv: } \left[\begin{array}{l} \text{RESULT} \\ \text{SOURCE} \end{array} \left[\begin{array}{l} \text{ARG-ST} \quad \langle \boxed{1}, \boxed{2}, \boxed{4} \langle \text{PRO}, \dots \rangle \rangle \\ \text{NEW-QS} \quad \boxed{6} \\ \text{ARG-ST} \quad \boxed{4} \\ \text{QSTORE} \quad \boxed{6} \end{array} \right] \right]$$

As a result, a causative stem, of type *caus-stem*, will obey the licensing constraints of *complex-pred-drv* above, and the further licensing constraints of *caus-drv*, and in addition the *caus-stem* will be subject to the revised version of the Quantifier Amalgamation Constraint. Application of the Quantifier Amalgamation Constraint to the *caus-stem* will allow there to be complements of the basic stem whose quantifiers scope over *caus-rel*, because the *caus-stem* inherits into its QSTORE any elements in the QSTORE of the stem (that is elements that were not scoped at the level of the stem), via the attribute NEW-QS. On the other hand, the input stem to *complex-pred-drv* may have ‘already scoped’ some of its quantifiers. That is, some quantifiers may appear in the SOURCE stem’s QUANTS value. Such elements will not appear in the QSTORE of the SOURCE stem (through the regular workings of the Quantifier Amalgamation Constraint), and so will not appear in the NEW-QS of the derived causative stem. At the level of the causative stem, the Quantifier Amalgamation Constraint collects only quantifiers in unembedded elements of the ARG-ST – this is where the function *toplevel* comes in – and adds to those quantifiers any as yet unscoped quantifiers in the NEW-QS set. As a result, each element of the ARG-ST will end up being retrieved precisely once. The subject of the embedded stem (the PRO coindexed with the causee) of course cannot contribute to the embedded stem’s QUANTS value, a fact that is simply accommodated if PRO’s QSTORE is assumed to be empty. By this mechanism, complements of the entire causative verb can be assigned scope within the EFFECT argument of *cause-rel*, but any elements that are not assigned narrow scope in this manner will be inherited by the causative stem and must be assigned wider scope somewhere within the sentence.

We illustrate in (78) one possible way of instantiating the constraints we have outlined for a causative stem, namely the one corresponding to the problematic reading of (77) – where *cause-rel* outscopes **3-books** which in turn outscopes *check-rel*:

²⁷The attribute NEW-QS is taken from Przepiórkowski (1997), where it is used in the lexical entry of quantifier words to introduce new quantifiers. His paper also presents a development and further formalization of the approach to lexicalizing quantifier scoping introduced here.

- (77) Tanaka-sensei ga gakusei ni sansatu hon o sirabe-sase-ta.
 Prof. Tanaka NOM student DAT three book ACC check-CAUS-PAST
 ‘Prof. Tanaka made the student check three books.’

(78)

<i>caus-stem</i>																							
PHON	<i>sirabesase</i>																						
SUBJ	$\langle \boxed{1}\text{NP}_i[\text{QS } \boxed{4}] \rangle$																						
COMPS	$\langle \boxed{2}\text{NP}_j[\text{QS } \boxed{5}], \boxed{3}\text{NP}_k[\text{QS } \boxed{6}] \rangle$																						
ARG-ST	$\langle \boxed{1}, \boxed{2}, \langle \text{PRO}_j, \boxed{3} \rangle \rangle$																						
QS	$(\boxed{4} \uplus \boxed{5} \uplus \boxed{7}) \ominus \boxed{8}$																						
NEW-QS	$\boxed{7}\{ \}$																						
CONT	<table style="border-collapse: collapse; margin-left: 2em;"> <tr> <td style="border-right: 1px solid black; padding-right: 1em;">QUANTS</td> <td>order($\boxed{8}$)</td> </tr> <tr> <td style="border-right: 1px solid black; padding-right: 1em;">NUCL</td> <td> <table style="border-collapse: collapse; margin-left: 2em;"> <tr> <td style="border-right: 1px solid black; padding-right: 1em;"><i>cause-rel</i></td> <td></td> </tr> <tr> <td style="border-right: 1px solid black; padding-right: 1em;">ACTOR</td> <td><i>i</i></td> </tr> <tr> <td style="border-right: 1px solid black; padding-right: 1em;">UNDERGOER</td> <td><i>j</i></td> </tr> <tr> <td style="border-right: 1px solid black; padding-right: 1em;">EFFECT</td> <td> <table style="border-collapse: collapse; margin-left: 2em;"> <tr> <td style="border-right: 1px solid black; padding-right: 1em;">QUANTS</td> <td>order($\boxed{6}$)</td> </tr> <tr> <td style="border-right: 1px solid black; padding-right: 1em;">NUCL</td> <td> <table style="border-collapse: collapse; margin-left: 2em;"> <tr> <td style="border-right: 1px solid black; padding-right: 1em;"><i>check-rel</i></td> <td></td> </tr> <tr> <td style="border-right: 1px solid black; padding-right: 1em;">ACTOR</td> <td><i>j</i></td> </tr> <tr> <td style="border-right: 1px solid black; padding-right: 1em;">UNDERGOER</td> <td><i>k</i></td> </tr> </table> </td> </tr> </table> </td> </tr> </table> </td> </tr> </table>	QUANTS	order($\boxed{8}$)	NUCL	<table style="border-collapse: collapse; margin-left: 2em;"> <tr> <td style="border-right: 1px solid black; padding-right: 1em;"><i>cause-rel</i></td> <td></td> </tr> <tr> <td style="border-right: 1px solid black; padding-right: 1em;">ACTOR</td> <td><i>i</i></td> </tr> <tr> <td style="border-right: 1px solid black; padding-right: 1em;">UNDERGOER</td> <td><i>j</i></td> </tr> <tr> <td style="border-right: 1px solid black; padding-right: 1em;">EFFECT</td> <td> <table style="border-collapse: collapse; margin-left: 2em;"> <tr> <td style="border-right: 1px solid black; padding-right: 1em;">QUANTS</td> <td>order($\boxed{6}$)</td> </tr> <tr> <td style="border-right: 1px solid black; padding-right: 1em;">NUCL</td> <td> <table style="border-collapse: collapse; margin-left: 2em;"> <tr> <td style="border-right: 1px solid black; padding-right: 1em;"><i>check-rel</i></td> <td></td> </tr> <tr> <td style="border-right: 1px solid black; padding-right: 1em;">ACTOR</td> <td><i>j</i></td> </tr> <tr> <td style="border-right: 1px solid black; padding-right: 1em;">UNDERGOER</td> <td><i>k</i></td> </tr> </table> </td> </tr> </table> </td> </tr> </table>	<i>cause-rel</i>		ACTOR	<i>i</i>	UNDERGOER	<i>j</i>	EFFECT	<table style="border-collapse: collapse; margin-left: 2em;"> <tr> <td style="border-right: 1px solid black; padding-right: 1em;">QUANTS</td> <td>order($\boxed{6}$)</td> </tr> <tr> <td style="border-right: 1px solid black; padding-right: 1em;">NUCL</td> <td> <table style="border-collapse: collapse; margin-left: 2em;"> <tr> <td style="border-right: 1px solid black; padding-right: 1em;"><i>check-rel</i></td> <td></td> </tr> <tr> <td style="border-right: 1px solid black; padding-right: 1em;">ACTOR</td> <td><i>j</i></td> </tr> <tr> <td style="border-right: 1px solid black; padding-right: 1em;">UNDERGOER</td> <td><i>k</i></td> </tr> </table> </td> </tr> </table>	QUANTS	order($\boxed{6}$)	NUCL	<table style="border-collapse: collapse; margin-left: 2em;"> <tr> <td style="border-right: 1px solid black; padding-right: 1em;"><i>check-rel</i></td> <td></td> </tr> <tr> <td style="border-right: 1px solid black; padding-right: 1em;">ACTOR</td> <td><i>j</i></td> </tr> <tr> <td style="border-right: 1px solid black; padding-right: 1em;">UNDERGOER</td> <td><i>k</i></td> </tr> </table>	<i>check-rel</i>		ACTOR	<i>j</i>	UNDERGOER	<i>k</i>
QUANTS	order($\boxed{8}$)																						
NUCL	<table style="border-collapse: collapse; margin-left: 2em;"> <tr> <td style="border-right: 1px solid black; padding-right: 1em;"><i>cause-rel</i></td> <td></td> </tr> <tr> <td style="border-right: 1px solid black; padding-right: 1em;">ACTOR</td> <td><i>i</i></td> </tr> <tr> <td style="border-right: 1px solid black; padding-right: 1em;">UNDERGOER</td> <td><i>j</i></td> </tr> <tr> <td style="border-right: 1px solid black; padding-right: 1em;">EFFECT</td> <td> <table style="border-collapse: collapse; margin-left: 2em;"> <tr> <td style="border-right: 1px solid black; padding-right: 1em;">QUANTS</td> <td>order($\boxed{6}$)</td> </tr> <tr> <td style="border-right: 1px solid black; padding-right: 1em;">NUCL</td> <td> <table style="border-collapse: collapse; margin-left: 2em;"> <tr> <td style="border-right: 1px solid black; padding-right: 1em;"><i>check-rel</i></td> <td></td> </tr> <tr> <td style="border-right: 1px solid black; padding-right: 1em;">ACTOR</td> <td><i>j</i></td> </tr> <tr> <td style="border-right: 1px solid black; padding-right: 1em;">UNDERGOER</td> <td><i>k</i></td> </tr> </table> </td> </tr> </table> </td> </tr> </table>	<i>cause-rel</i>		ACTOR	<i>i</i>	UNDERGOER	<i>j</i>	EFFECT	<table style="border-collapse: collapse; margin-left: 2em;"> <tr> <td style="border-right: 1px solid black; padding-right: 1em;">QUANTS</td> <td>order($\boxed{6}$)</td> </tr> <tr> <td style="border-right: 1px solid black; padding-right: 1em;">NUCL</td> <td> <table style="border-collapse: collapse; margin-left: 2em;"> <tr> <td style="border-right: 1px solid black; padding-right: 1em;"><i>check-rel</i></td> <td></td> </tr> <tr> <td style="border-right: 1px solid black; padding-right: 1em;">ACTOR</td> <td><i>j</i></td> </tr> <tr> <td style="border-right: 1px solid black; padding-right: 1em;">UNDERGOER</td> <td><i>k</i></td> </tr> </table> </td> </tr> </table>	QUANTS	order($\boxed{6}$)	NUCL	<table style="border-collapse: collapse; margin-left: 2em;"> <tr> <td style="border-right: 1px solid black; padding-right: 1em;"><i>check-rel</i></td> <td></td> </tr> <tr> <td style="border-right: 1px solid black; padding-right: 1em;">ACTOR</td> <td><i>j</i></td> </tr> <tr> <td style="border-right: 1px solid black; padding-right: 1em;">UNDERGOER</td> <td><i>k</i></td> </tr> </table>	<i>check-rel</i>		ACTOR	<i>j</i>	UNDERGOER	<i>k</i>				
<i>cause-rel</i>																							
ACTOR	<i>i</i>																						
UNDERGOER	<i>j</i>																						
EFFECT	<table style="border-collapse: collapse; margin-left: 2em;"> <tr> <td style="border-right: 1px solid black; padding-right: 1em;">QUANTS</td> <td>order($\boxed{6}$)</td> </tr> <tr> <td style="border-right: 1px solid black; padding-right: 1em;">NUCL</td> <td> <table style="border-collapse: collapse; margin-left: 2em;"> <tr> <td style="border-right: 1px solid black; padding-right: 1em;"><i>check-rel</i></td> <td></td> </tr> <tr> <td style="border-right: 1px solid black; padding-right: 1em;">ACTOR</td> <td><i>j</i></td> </tr> <tr> <td style="border-right: 1px solid black; padding-right: 1em;">UNDERGOER</td> <td><i>k</i></td> </tr> </table> </td> </tr> </table>	QUANTS	order($\boxed{6}$)	NUCL	<table style="border-collapse: collapse; margin-left: 2em;"> <tr> <td style="border-right: 1px solid black; padding-right: 1em;"><i>check-rel</i></td> <td></td> </tr> <tr> <td style="border-right: 1px solid black; padding-right: 1em;">ACTOR</td> <td><i>j</i></td> </tr> <tr> <td style="border-right: 1px solid black; padding-right: 1em;">UNDERGOER</td> <td><i>k</i></td> </tr> </table>	<i>check-rel</i>		ACTOR	<i>j</i>	UNDERGOER	<i>k</i>												
QUANTS	order($\boxed{6}$)																						
NUCL	<table style="border-collapse: collapse; margin-left: 2em;"> <tr> <td style="border-right: 1px solid black; padding-right: 1em;"><i>check-rel</i></td> <td></td> </tr> <tr> <td style="border-right: 1px solid black; padding-right: 1em;">ACTOR</td> <td><i>j</i></td> </tr> <tr> <td style="border-right: 1px solid black; padding-right: 1em;">UNDERGOER</td> <td><i>k</i></td> </tr> </table>	<i>check-rel</i>		ACTOR	<i>j</i>	UNDERGOER	<i>k</i>																
<i>check-rel</i>																							
ACTOR	<i>j</i>																						
UNDERGOER	<i>k</i>																						

Thus these lexical types allow exactly the desired result – the direct object of the lower verb may contribute a quantifier that scopes wide or narrow with respect to *caus-rel*. In the case of (77), the QSTORE of the NP *sansatu-no hon-o* is the singleton set **{3-books}**, and this will serve to instantiate the tag $\boxed{6}$ in (78), thus producing the desired narrow scope assignment.

In sum, the lexically based revision of the Pollard/Yoo theory of quantifier storage and quantifier scoping that we have sketched seems to fit well with our theory of Japanese causatives. Although complex words of Japanese preserve their lexical integrity (Bresnan and Mchombo 1995), NPs external to those words may still be assigned scope intermediate to the semantic elements of a lexicalized complex predicate like a causative. This result follows once verbal stems, rather than syntactic phrases or words, are taken as the locus for quantifier scope assignment.

4.4 Passives

A final point to be addressed is the interaction of causativization with passivization. It is well-known (e.g. Kuno 1973) that causatives of transitive verbs allow passivization of the *-ni* marked phrase, but not of the *-o* marked (lower) object, as in (79).²⁸

²⁸Ishikawa (1985) questions this generalization suggesting that passivization is possible in examples such as *Hukei o yorokob-aseru tame, toku-ni muzukasii zi ga kodomotati ni kak-ase-rare-ta* ‘In order to impress the parents, particularly difficult characters were caused (by the teachers) to be written by the children.’

- (79) a. Mitiko ga Taroo ni Ziroo o yob-ase-ta.
 Mitiko NOM Taroo DAT Ziroo ACC call-CAUS-PAST
 ‘Mitiko made Taroo call Ziroo.’
- b. Taroo ga Mitiko ni Ziroo o yob-ase-rare-ta.
 Taroo NOM Mitiko by Ziroo ACC call-CAUS-PASS-PAST
 ‘Taroo was made by Mitiko to call Ziroo.’
- c. *Ziroo ga Mitiko ni(-yotte) Taroo ni yob-ase-rare-ta.
 Ziroo NOM Mitiko by Taroo DAT call-CAUS-PASS-PAST
 ‘(lit.) Ziroo was made called by Taroo by Mitiko.’

In contrast, monomorphemic ditransitive verbs allow passivization of either object.

Here we adopt Hasegawa’s (1981) suggestion that passivization of the lower object is impossible because it doesn’t have a thematic role (i.e. it is not the value of a role attribute) in the top-level CONTENT of the clause. This suggestion receives independent support from the fact that this constraint appears to hold generally in Japanese.

First, (80) shows that idioms (whose argument we assume not to be assigned a thematic role), cannot passivize (Yatabe 1990):

- (80) a. Kenitiroo ga saba o yon-da
 Kenitiroo NOM mackerel ACC read-PAST
 ‘Kenichiroo gave a false count.’
- b. *saba ga Kenitiroo ni yom-are-ta
 mackerel NOM Kenitiroo DAT read-PASS-PAST

Further, Kuno (1976) argues that (81a) is an example of raising-to-object in Japanese and he notes that the raised object fails to passivize as can be seen in (81b).

- (81) a. Noriko ga Masaru o hannin da to omot-ta.
 Noriko NOM Masaru ACC culprit is COMP think-PAST
 ‘Noriko thinks Masaru to be the culprit.’
- b. *Masaru ga Noriko ni hannin da to omow-are-ta.
 Masaru NOM Noriko DAT culprit is COMP think-PASS-PAST
 ‘Masaru was thought to be the culprit by Noriko.’

Thus the failure of passivization is expected on independent grounds, and provides no evidence against the merged argument structures embodied in our analysis.

But our surveys suggest that such examples are judged unacceptable by the vast majority of Japanese native speakers.

5 Conclusion

This paper began by mentioning the many phenomena that motivate a lexical analysis of Japanese causatives. Such phenomena support the Lexical Integrity Principle of Bresnan and Mchombo (1995), and argue that Japanese causatives behave as a single clause with respect to case, word order, and similar properties. In addition, we have examined the diverse phenomena that have been assumed to motivate the multiclausal analysis of Japanese causatives, reaching the conclusion that all such data are handled at least as well or better within our single-clause, embedded argument structure approach.

The solutions we have been led to bear on larger issues than the particulars of Japanese grammar discussed here. For example, our proposed solution to the problems posed by the interaction of adverb scope and causatives builds crucially on an analysis where heads select for their modifiers, rather than the familiar treatment where adjuncts select for the phrases that they combine with syntactically. The theory we have sketched here, unlike the more familiar alternative, provides a uniform account of both sublexical and supralelexical scoping, and hence may deserve consideration as the basis for the treatment of adverbs more generally. Similarly, our lexicalized account of quantifier scoping, which eliminates syntactic retrieval entirely from the theory of Cooper storage, allows sublexical scoping of a sort that is inconsistent with other approaches, including that of Pollard and Yoo (forthcoming).

We started out with Kiparsky's observation on the non-arbitrariness of the diverse properties that causative constructions exhibit. The account we have developed provides the beginnings of an explanation for the duality of causatives. Since case marking, agreement and word order are all determined by the interaction of principles constraining the way lexical items can appear in constituent structures, it follows that, with respect to these properties, morphological causatives behave just like other words of similar valence, exhibiting essentially all the properties of single lexical items. But construal processes such as honorification, binding and quantifier floating are in general sensitive to argument structure, as Yatabe (1993) and Manning (1994) have observed. Thus our analysis of causative constructions in terms of complex argument structures leads us to predict evidence of embedding with all and only phenomena of this type. We find these results highly suggestive, not just for the treatment of causatives, but for the design of grammar in the broadest sense.

Bibliography

- Abeillé, Anne and Danièle Godard. 1994. The Complementation of tense auxiliaries in French. In *Proceedings of the Thirteenth West Coast Conference on Formal Linguistics*. Stanford: SLA, CSLI Publications. Pp. 157–172.
- Alsina, Alex. 1993. *Predicate Composition: A Theory of Syntactic Function Alternations*, Doctoral dissertation. Stanford University.
- Borsley, Robert. 1989. Phrase-Structure Grammar and the *Barriers* Conception of Clause Structure. *Linguistics* 27: 843–863.
- Bresnan, Joan and Annie Zaenen. 1990. Deep unaccusativity in LFG. In *Grammatical Relations. A Cross-Theoretical Perspective*, ed. by Katarzyna Dziwirek, Patrick Farrell, and Errapel Mejías-Bikandi. Stanford: SLA, CSLI Publications. Pp. 45–57.
- Bresnan, Joan and Sam A. Mchombo. 1995. The Lexical Integrity Principle: Evidence from Bantu. *Natural Language and Linguistic Theory* 13: 181–254.
- Butt, Miriam. 1993. *The Structure of Complex Predicates: Evidence from Urdu*, Doctoral dissertation. Stanford University.
- Chew, J. 1961. *Transformational Analysis of Modern Colloquial Japanese*. Doctoral Dissertation. Yale University.
- Cooper, Robin. 1983. *Quantification and Syntactic Theory*. Dordrecht: Reidel.
- Copetake, Ann. 1992. *The Representation of Lexical Semantic Information*. Cognitive Science Research Papers 280. University of Sussex.
- Davis, Anthony. 1996. *Lexical Semantics and Linking in the Hierarchical Lexicon*. Doctoral dissertation. Stanford University.
- Flickinger, Daniel. 1987. *Lexical Rules in the Hierarchical Lexicon*. Doctoral dissertation. Stanford University.
- Grimshaw, Jane. 1990. *Argument Structure*. Cambridge, Mass.: MIT Press.
- Gunji, Takao. 1987. *Japanese Phrase Structure Grammar: A Unification-Based Approach*. Dordrecht: Reidel.
- Harada, S.-I. 1973. Counter-Equi NP Deletion, Research Institute of Logopaedics and Phoniatrics, University of Tokyo. *Annual Bulletin* 7: 113–148.
- Hasegawa, Nobuko. 1981. Lexicalist Grammar and Japanese Passives. *Coyote Papers* 2: 25–40. University of Arizona, Tucson.
- Hinds, John. 1973. Some Remarks on *Soo Su-*. *Papers in Japanese Linguistics* 2: 18–30.

- Iida, Masayo. 1992. *Context and Binding in Japanese*. Doctoral dissertation. Stanford University.
- Iida, Masayo. 1996. *Context and Binding in Japanese*. Stanford: CSLI Publications.
- Ishikawa, Akira. 1985. *Complex Predicates and Lexical Operations in Japanese*. Doctoral dissertation. Stanford University.
- Kathol, Andreas. 1995. *Linearization-Based German Syntax*. Doctoral dissertation. Ohio State University.
- Kiparsky, Paul. 1982. Lexical Morphology and Phonology. In *Linguistics in the morning calm*, ed. by The Linguistic Society of Korea. Seoul: Hanshin. Pp. 3–91.
- Kiparsky, Paul. 1987. Morphology and Grammatical Relations. MS, Stanford University.
- Kim, Jong-Bok and Ivan A. Sag. 1995. The Parametric Variation of English and French Negation. In *Proceedings of the Fourteenth West Coast Conference on Formal Linguistics*. Stanford: SLA, CSLI Publications.
- Kitagawa, Yoshihisa. 1986. *Subjects in Japanese and English*. Doctoral dissertation. University of Massachusetts, Amherst. [Published by Garland, New York, 1994.]
- Kuno, Susumu. 1973. *The Structure of the Japanese Language*. Cambridge, Mass.: MIT Press.
- Kuno, Susumu. 1976. Subject Raising in Japanese. In *Syntax and Semantics 5: Japanese Generative Grammar*, ed. by Masayoshi Shibatani. New York: Academic Press. Pp. 17–49.
- Kuroda, Sige-Yuki. 1965. *Generative Grammatical Studies in the Japanese Language*. Doctoral dissertation. Massachusetts Institute of Technology.
- Kuroda, Sige-Yuki. 1981. Some Recent Trends in Syntactic Theory and the Japanese Language. *Coyote Papers* 2: 103–121. University of Arizona, Tucson.
- Manning, Christopher D. 1994. *Ergativity: Argument Structure and Grammatical Relations*. Doctoral dissertation. Stanford University.
- Manning, Christopher D. 1996. *Ergativity: Argument Structure and Grammatical Relations*. Stanford: CSLI Publications.
- Manning, Christopher D. and Ivan A. Sag. to appear. Argument Structure in HPSG: Modeling valency alternations and binding. *Nordic Journal of Linguistics*, 21, 1998.
- Marantz, Alec. 1982. Re Reduplication. *Linguistic Inquiry* 13: 435–482.
- McCawley, James D. 1968. *The Phonological Component of a Grammar of Japanese*. The Hague, Mouton.

- Meurers, Detmar. 1995. Towards a Semantics for Lexical Rules as used in HPSG. Paper presented at the Conference on Formal Grammar, Barcelona, Spain, at the Tübingen HPSG workshop, and the ACQUILEX II Workshop on Lexical Rules, Cambridge, UK. [Revised version available at <http://www.sfs.nphil.uni-tuebingen.de/dm/>.]
- Miller, Philip H. 1991. *Clitics and Constituents in Phrase Structure Grammar*. Doctoral dissertation. Rijksuniversiteit Utrecht. [Published by Garland, New York, 1993.]
- Miller, Philip H. and Ivan A. Sag. 1997. French Clitic Movement Without Clitics or Movement. *Natural Language and Linguistic Theory* 15: 573–639.
- Miyagawa, Shigeru. 1980. Complex Verbs and the Lexicon. *Coyote Working Papers 1*. University of Arizona, Tucson.
- Miyagawa, Shigeru. 1989. *Structure and Case Marking in Japanese*. San Diego: Academic Press.
- Momoi, Katsuhiko. 1985. Semantic Roles, Variation, and the Japanese Reflexive. *University of Chicago Working Papers in Linguistics* 1: 73–92.
- Montague, Richard. 1974. The Proper Treatment of Quantification in Ordinary English. In *Formal Philosophy*, ed. by Richmond Thomason. New Haven: Yale University Press.
- Muraki, Masatake. 1978. The *sika nai* Construction and Predicate Restructuring. In *Problems in Japanese Syntax and Semantics*, ed. by John Hinds and Irwin Howard. Tokyo: Kaitakusya. Pp. 155–177.
- Pollard, Carl and Ivan A. Sag. 1987. *Information-Based Syntax and Semantics*, Vol. 1. CSLI Lecture Notes Series 13. Stanford: CSLI Publications.
- Pollard, Carl and Ivan A. Sag. 1992. Anaphors in English and the Scope of Binding Theory. *Linguistic Inquiry* 23: 261–303.
- Pollard, Carl and Ivan A. Sag. 1994. *Head-Driven Phrase Structure Grammar*. Chicago: University of Chicago Press and Stanford: CSLI Publications.
- Pollard, Carl and Eun Jung Yoo. forthcoming. A Unified Theory of Scope for Quantifiers and *Wh*-Phrases. To appear in *Journal of Linguistics*.
- Poser, William J. 1984. The Phonetics and Phonology of Tone and Intonation in Japanese. Doctoral Dissertation. MIT.
- Poser, William J. 1989. What is the ‘Double-*o* Constraint’ a Constraint On? MS, Stanford University.
- Poser, William J. 1992. Blocking of Phrasal Constructions by Lexical Items. In *Lexical Matters*, ed. by Ivan Sag and Anna Szabolcsi. Stanford: CSLI Publications.
- Przepiórkowski, Adam. 1997. Quantifiers, Adjuncts as Complements, and Scope Ambiguities. MS, University of Tübingen.

- Rappaport, Malka and Beth Levin. 1988. What to do with theta-roles. In *Syntax and Semantics, Vol. 21: Thematic Relations*, ed. by Wendy Wilkins. San Diego: Academic Press.
- Riehemann, Susanne. 1993. *Word Formation in Lexical Type Hierarchies: A Case Study of bar-Adjectives in German*. Master's thesis. University of Tübingen.
- Riehemann, Susanne. 1995. Type-Based Morphology. MS, Stanford University.
- Sag, Ivan A., and Carl Pollard. 1991. An Integrated Theory of Complement Control. *Language* 67: 63-113.
- Saiki, Mariko. 1987. *On the Manifestations of Grammatical Functions in the Syntax of Japanese Nominals*. Doctoral dissertation. Stanford University.
- Shibatani, Masayoshi. 1973. Semantics of Japanese causativization. *Foundations of Language* 9: 327–373.
- Shibatani, Masayoshi. 1990. *The Languages in Japan*. Cambridge: Cambridge University Press.
- Sugioka, Yoko. 1984. *Interaction of Derivational Morphology and Syntax in Japanese and English*. Doctoral dissertation. University of Chicago.
- Takubo, Yukinori. 1990. On the Role of Hearer's Territory of Information—A Contrastive Study of Dialogic Structure in Japanese, Chinese, and English as Manifested in the Third Person Pronoun System. In *Advances in Japanese Cognitive Science* Vol. 3. Tokyo: The Japanese Cognitive Science Center. Pp. 66–84.
- Van Noord, Gertjan, and Gosse Bouma. 1994. Adjuncts and the Processing of Lexical Rules. *Proceedings of Coling 1994*, Kyoto. Pp. 250–256.
- Wechsler, Stephen. 1995. *The Semantic Basis of Argument Structure*. Stanford: CSLI Publications.
- Xue, Ping, Carl Pollard, and Ivan A. Sag. 1994. A New Perspective on Chinese *Ziji*. In *Proceedings of the Thirteenth West Coast Conference on Formal Linguistics*. Stanford: SLA, CSLI Publications. Pp. 432–447.
- Yatabe, Shûichi. 1990. The Representation of Idioms. MS, Stanford University.
- Yatabe, Shûichi. 1993. *Scrambling and Japanese Phrase Structure*. Doctoral dissertation. Stanford University.